



Hybrid and Electric Vehicles



Belief in technology

Contents

03	Leading In Transportation Technology
04	Hybrid & Electric Vehicle Sectors
05	HEVs and the Environment
06-09	Key Applications
10	Car Cut-away
11	Contact Us



Leading in Transportation Technology

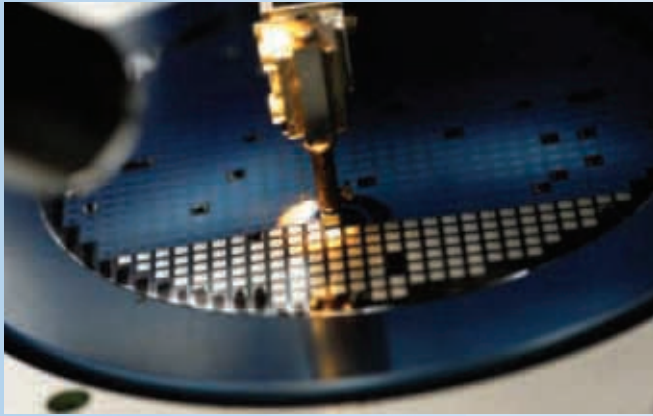

TT electronics continues to develop leading edge technology, consolidating its position as a major supplier to the global automotive and transportation markets.

With over 25 years of experience in the design, development and manufacture of system critical sensors for powertrain, safety and chassis applications to global transportation customers, TT electronics has a proven pedigree.

TT electronics has created a virtual market team for the growing hybrid and electrical vehicle sector (HEV), to improve focus and capture and share technology opportunities. This virtual team approach helps us to significantly increase our knowledge and understanding of the HEV market and enables us to be more responsive to our customers.

We are proud to be associated with many of the leading global suppliers of automotive and transportation, many of whom return to TT electronics time and time again for new projects and products.

Hybrid & Electric Vehicle Sectors

Passenger Cars

- **Luxury Cars**
- **SUVs**
- **Minivans**
- **4x4s**
- **Ultra Low Cost Cars**

Despite the ongoing debate on how green HEVs really are, there is no doubt that this vehicle segment will continue to grow as a result of consumer pressure and government incentives. Continued developments in lighter, ever more efficient technology and the adoption of innovative range extenders will significantly contribute to the increased popularity of vehicles powered by HEV power plants.



Trucks

- **Heavy Vehicles**
- **Commercial Vehicles**
- **Military Vehicles**
- **Special Vehicles**

Analysis suggests that the North American and European hybrid truck, bus and van market is expected to grow from 4,100 units in 2009 to 222,000 units by 2016*. Amongst alternative powertrain technologies and fuels, hybrid commercial vehicles exert the least pressure on the existing energy and transportation infrastructure and require only minimal modification to the current fuelling infrastructure.



Buses

- **Buses**
- **Coaches**

Compared with diesel buses, hybrid buses deliver the following environmental benefits:

- at least a 30% reduction in fuel use
- at least a 30% reduction in carbon dioxide
- 3 decibel [dB(A)] reduction in perceived sound levels
- Reduced oxides of nitrogen and carbon monoxide

Increasing environmental awareness by governments and city authorities will result in incentives for the wider use of hybrid and electric powered city transport vehicles. Regular routes, timetable and the predictable usage of a city transport vehicle are key factors that contribute to the suitability of HEV transport.



2 & 3 wheel Personal Transport

- **Motorbikes**
- **Rickshaws**
- **2 & 3 wheelers**

Reports anticipate that the global market for electric two-wheeled e-bikes, e-scooters, and e-motorcycles will grow at a compound annual rate of 9% through 2016*. Two-wheel vehicles commanded 98% of the global market in 2009. China's compound annual growth rate (CAGR) of 8.2% between 2009 and 2016 will contribute to Asia-Pacific's sales of 78.6 million electric two-wheel vehicles in 2016 (with a CAGR of 8.9% for the region overall), according to the report, "Electric Two-Wheel Vehicles Electric Bicycles, Mopeds, Scooters, and Motorcycles".



* Trucks - Frost & Sullivan. 2 & 3 wheelers - Pike Research

HEVs and the Environment

TT electronics companies adopt a responsible attitude towards the protection of the environment.

We strive to meet the requirements of all applicable environmental laws and regulations, to continuously improve environmental performance and to contribute to long-term economic, environmental and social sustainability.

As part of TT electronics' Group Corporate Social Responsibility (CSR) Programme, we engage with industry bodies, like the Electronics Industry Citizenship Coalition (EICC) and Carbon Trust, to support these goals and to maintain ethical supply chains.

The CSR programme has opened up a network for TT electronics, across industry leading bodies, helping us to benchmark our environmental approach.

Environmental Deployment:

- Each site is encouraged to attain the latest quality and environmental accreditation and companies have attained ISO 9001, ISO 14001, QS 900 and TS16949, where appropriate.
- Our companies utilise energy efficient means of manufacture and seek to reduce, reuse and recycle waste and arrange for disposal of other waste responsibly.

In collaboration with customers and suppliers, TT electronics' product and process development engineers work continuously to meet the demands of a more environmentally demanding market place. With every new vehicle platform, the increasing use of electronics enables improved techniques to be utilised for reducing emissions and improving fuel economy. The continued drive for a cleaner environment is behind research and development into future generations of vehicles and personal transport systems. Many of these will incorporate new and novel forms of power plants including hybrid engines, fuel cells and plug in electrics. These exciting and technically advanced power sources will be controlled using new generations of electronic functional systems incorporating technology from TT electronics in the form of components and systems.

TT electronics companies have invested, heavily, in design engineering, process control and modern manufacturing equipment. An essential part of product development is the validation of products to customer specific requirements. In most of our companies, this process is carried out in-house on independently certified test and validation facilities. We are committed to partnerships with suppliers and encourage a talented, fully involved and committed workforce to achieve our objectives.

Each of our businesses adopts a high level of customer focus, and is committed to continuous improvement by utilising tools and methods including lean manufacture, Kaizen and Six- Sigma.

We believe that the ultimate measure of quality is customer satisfaction and that continued growth must be based on optimising and improving our quality performance.



HEV Key Applications –

The Hybrid Electric Vehicle (HEV) in simple terms is the combination of an internal combustion engine (ICE) with one or more electric motor/generators and a battery pack. It combines the propulsion system with a rechargeable energy storage system (RESS) and gets better fuel economy.

The two drive mechanisms in HEV are in **parallel** or in **series** systems:

In **parallel** hybrids, the ICE and the electric motor are both connected to the mechanical transmission and can simultaneously transmit power to drive the wheels, usually through a conventional transmission. Current, commercialized parallel hybrids use a single, small (<20 kW) electric motor and small battery pack as the electric motor is not designed to be the sole source of motive power from launch. Parallel hybrids are also capable of regenerative braking and the internal combustion engine can also act a generator for supplemental recharging.

In **series** hybrids, only the electric motor drives the drivetrain, and the ICE works as a generator to power the electric motor or to recharge the batteries. The battery pack can be recharged from regenerative braking or from the ICE. Series hybrids usually have a smaller combustion engine but a larger battery pack as compared to parallel hybrids, which makes them more expensive than parallels. This configuration makes series hybrids more efficient in city driving.

HEV Efficiency Factors:

- Engine Stop/Start when vehicle at standstill
- Regenerative Braking to charge batteries
- Smaller engine size and reduced emissions
- Vehicle weight and aerodynamic design

Stop/Start technology claims to reduce fuels consumption by up to 15% in normal driving and some European sources predict that one in every two new cars produced in 2012 will have start/stop technology.

The energy efficiency of a conventional car is only about 20%, with the remaining 80% of its energy being converted to heat through friction. The miraculous thing about regenerative braking is that it may be able to capture as much as half of that wasted energy and put it back to work. This could reduce fuel consumption by 10% to 25%. Hydraulic regenerative braking systems could provide even more impressive gains, potentially reducing fuel use by 25% to 45%.

The HEV market growth due to consumer demand, governmental regulations and supported by subsidies, has created a rapid technology evolution for the vehicle manufacturers and their suppliers across the transportation industry. TT electronics has been involved at the forefront of vehicle electronic technology development for a number of years and intends to continue the expansion of its product offering by working in partnership with the manufacturers and tier 1 suppliers on HEV applications.

The key elements of TT electronics' technology development and product offering into the HEV market are two-fold:

- 1) **The further development of the current range of vehicle sensors, components, and systems to offer lighter weight, improved reliability, and reduced cost of ownership.**

Examples are: Position sensors on the engine and chassis, temperature sensing, control units, power module inverters for pumps, and resistive, optoelectronic, and magnetic components.
- 2) **Leading technology development partnerships with customers solving the functionality issues on maximising the efficiency, reliability, cost, as well as more extreme temperature, thermal performance, and resilience to fluid and dirt ingress.**

Examples are: Stop/Start power modules, micro inverter modules, high power inverters 100kW, inductive position sensors AutoPad™, current sense and transient resistors.

The technology challenges in HEV requires state-of-the-art solutions to each of the functional systems blocks of: high-power energy storage systems, integrated high-power electronics, regenerative power systems, robust sensing systems operating in high voltage environments, voltage conversion, charge management, energy dump, transient suppression, and current measurement.

With the added focus of the virtual market team, TT electronics intends to be one of the leading technology suppliers in this evolving sector.

Case Study

HEV is one of the key drivers on the technology development of applying Silicon Carbide (SiC) in semiconductor manufacture and into electronic circuits for power modules.

SiC provides application advantages in HEV:

- Greater power density
- Lower switching losses
- Higher operating frequencies
- Higher operating temperature

The requirement for high temperature electronics in HEV applications of under-the-hood, in the wheel, or integrated into the motor, will be a technology driver for SiC in both the semiconductor and the electronics module substrates.

TT electronics is today exploiting this advanced material in both research and manufacturing with the result that more automotive manufacturers and suppliers, existing and new, are engaging with us on multiple applications.

Although SiC is expensive today, the expansion of the adoption by semiconductor companies to meet the application demands and the utilisation of larger diameter wafers should result in significant cost reduction. The expansion and success of SiC will be the catalyst for the emergence of Gallium Nitride (GAN) as a high temperature wide band gap semiconductor for the HEV market which could promise improved performance cost ratios.

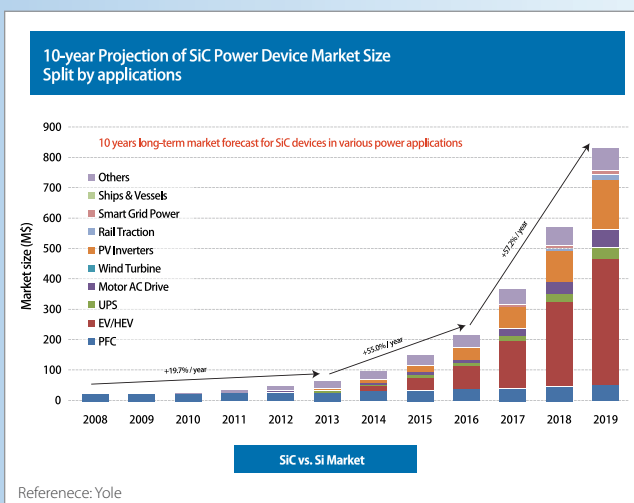

The graph depicts the rapid up take of SiC over the coming decade in a number of key power electronics application areas especially HEV.

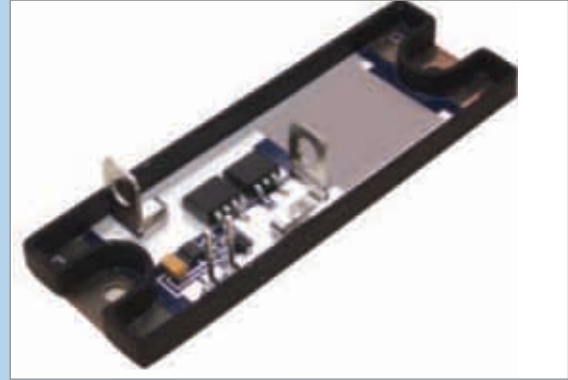

Battery Management

An electrical ballast infrastructure needs to be developed, globally, to accommodate and keep HEVs moving.

The electrical ballast network module is connected between the battery and the vehicle electrical harness. The Insulated Gate Bipolar Transistor (IGBT) and resistor network basically absorbs any surges protecting the battery from any transients balancing the voltage networks. The ballast network serves to reduce and share current that is drawn from the alternator stabilizing the vehicle voltage supply.

When the power requirement has been reduced, the network blends the battery recharging current back in a controlled manner. In order to use an electric drive in an optimum way, the available energy must also be used efficiently. Energy flow regulation must be a controlled process under any operating condition, which also requires a continuous measurement of current and voltage.

The technology challenges of this ballast network function involves voltages of up to 800 V, a current range from 10 mA to 150 A with 1.5 kA peaks with precision measurement to 0.1%.

HEV battery ballast management products bring together TT electronics' technologies to provide reliable cost effective solutions for the customer. Our technology expertise in surface mount, thick and thin film ceramic (active and passive) processing, 3D encapsulation and thermal design, power component assembly and test come together in advanced, compact structures that are predicted to be in great demand as EV/HEV applications gather pace in the 'greener society'.

TT electronics aims to maintain its position at the forefront of these technologies in order to satisfy these ever changing demands.

Key Applications – Thick Film Platform Technologies

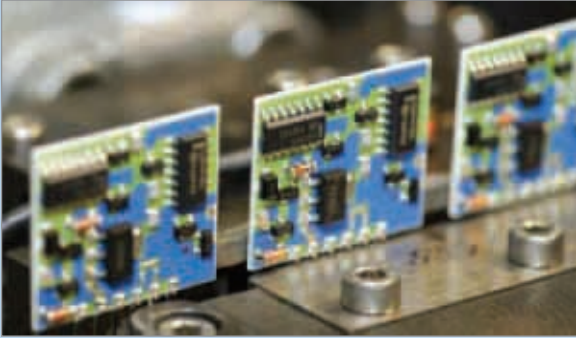

TT electronics companies have been designing and manufacturing thick and thin film products for over 30 years and are global leaders in advanced performance products.

For the HEV market challenges, TT electronics is applying this thick film application knowledge and process competence to provide a range of high reliability products including: high temperature electronic modules, rugged electronics integrated with mechanical functions, power, precision and pulse resistors, LED lighting modules, inverter modules, voltage converters, sensors and systems.

High Temperature and Rugged Electronic Modules

Thick film alumina or metal substrate technology combined with conductive and resistive ink printing and firing processes provides TT electronics with a platform to integrate control and power electronic circuitry. The application of our PATCHWORK combines Ag/Pd/Pt, copper and gold conductors, high temperature solder, window framing design and efficient thermal properties, to deliver application integrated solutions for HEVs. Our technologies are complemented by a responsive customer focused engineering team with extensive knowledge of thick film materials, packaging, partitioning, and testing for performance, reliability, and cost.

The result is a fast and economic engineering turnaround service, combined with world class investment in automated manufacturing, providing the customer with a competitive high reliability and tested product to improve their time-to-market.

Our customers recognise this asset and continually return to us, to involve us in the early concept and development stages of their new product creation process.

Resistors

High performance and high reliability resistors are at the heart of many HEV applications including:

- Inrush Current Limiting Resistors
- Battery Charging Systems
- Inverters
- Load Dump and Transient Resistors
- Capacitor Discharge
- Fuel Cell Load Dump and Management
- Kinetic Energy Recovery System Overload (KERS)
- Active Battery Cell Balancing
- Current Sense
- Power Management on High Voltage Buses
- Resistive Heaters

Specialist resistor technology is widely used in hybrid and electric vehicles and we work with customers on multiple HEV applications. A key area is inrush current limiting and capacitance discharge.

HEV battery banks require high voltage, capacitors to filter and maintain the charging system voltage. TT electronics has adapted and validated its high wattage wirewound resistors to both limit the inrush current to these capacitors as well as perform the discharge function. The resistors are located in the Battery Disconnect Unit (BDU). Most BDU designs also include the main fuse for the high voltage bus, switching relays, and manual service disconnect within the module. System voltage ranges are seen from 138 Vdc for Battery Assist Start Vehicles, (BAS), up to 420Vdc on a full Plug in Hybrid (PHEV). The BDU module is a standard system for all HEV charging systems.

Sensors

Meeting EMC requirements is one of the key technical challenges resulting from the global shift towards the engineering of efficient and manufacturable electric drive vehicle propulsion systems. This is necessary to ensure customer satisfaction, meet legal requirements and to support mission performance goals. Many of the existing methods are based upon "legacy" low voltage components and systems.

Inductive sensing methods are emerging as the platform technology of choice for position sensors. Compared with Hall-effect sensors, TT electronics' proprietary AutoPad™ offers vastly improved susceptibility performance in the presence of the strong magnetic field encountered close to HEV power plants. AutoPad™ is fully configurable for rotary and linear measurement applications.

Inverters

TT electronics is actively developing a range of high power inverters for a wide variety of HEV drivetrain applications for a number of prestigious vehicle manufacturers. These inverters have power capabilities of a few kilowatts to many 100s of kilowatts. They employ the latest thermal management materials and circuit topologies to keep the active semiconductor devices operating at temperatures that will ensure product longevity and class leading reliability.

The designs focus on power electronic cost reduction. Inclusion of high temperature semiconductors such as SiC and GaN for under bonnet applications in areas of high temperature is also being actively addressed, given the increasing importance of these semiconductors in power system applications.

DC-DC Converters and AC-DC

The new electrical architecture in the HEV designs now requires a high voltage bus beyond the standard 12 Vdc operating system. The need for inverters and converters is now required to provide power at voltage levels to support the BAS from the vehicle charging system. The energy either stored or dissipated from the high voltage battery packs requires conversion to interconnect with the traditional 12 V system. PHEV store energy at even higher levels and utilize both the Inverters for the plug in charging system as well as the converters for the on board charging system.

Optoelectronics and Lighting Solutions

TT electronics continues to expand the optoelectronic range of products for vehicles with infrared sensing products and visible LED components and modules.

TT electronics is providing custom external LED lighting clusters for indication, braking, daylight running, and the development of high power for headlight full beam.

In lighting applications the management of the 3 critical thermal junctions is further enhanced by TT electronics' patented Anotherm®Plus Technology, providing an extremely efficient thermal interface to the housing of the lamp.

By combining our thick film knowledge and visible LED competence, we can address the thermal performance issues to provide the customer with high power products that meet the extended life reliability expectations within a defined wavelength and lumens output.

Case Study

AB Mikroelektronik has worked with Protean Electric to develop advanced modules for in-wheel electric drive.

The new micro inverter/power electronic module is a rugged high reliability device designed to withstand water and dirt ingress and be resistant to shock and vibration. Each of Protean's in-wheel motors contains multiple drive modules enabling vehicle performance that matches the performance of traditional 2-wheel and 4-wheel drive vehicles.

Our competence is not just limited to cars. A further example is a compact control unit for a KTM motorcycle due for launch early 2011. The compact control unit converts the high voltage of 300V for the motor control to 12V for controlling smaller electronic devices like horn, blinker or light. Leading car manufacturers have also shown great interest in this technology, which won the 2010 Salzburg Innovation Award.

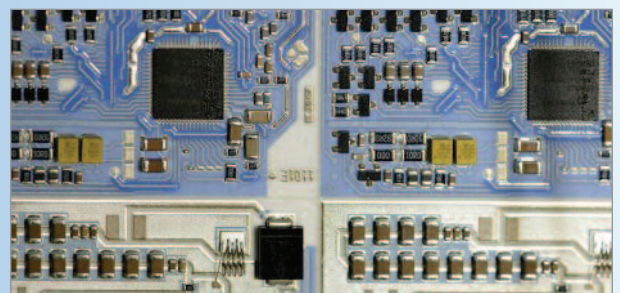

Car Cutaway

Windscreen Wipers



Surge Protection Resistor for Wiper & Control Module



Camshaft / Crankshaft Sensor

Lights



LEDs - Internal and Exterior

Braking System / Wheels



Brake Position Sensor



In-wheel Motor Drive Module

Steering Sensors



Steering Torque & Position Sensor

Windows



Current Sense Resistor for Window Lifts, Doors, & Seat Belt Tension

Bonnet/engine



Speed Sensor



Pressure Sensor



Temperature Sensor

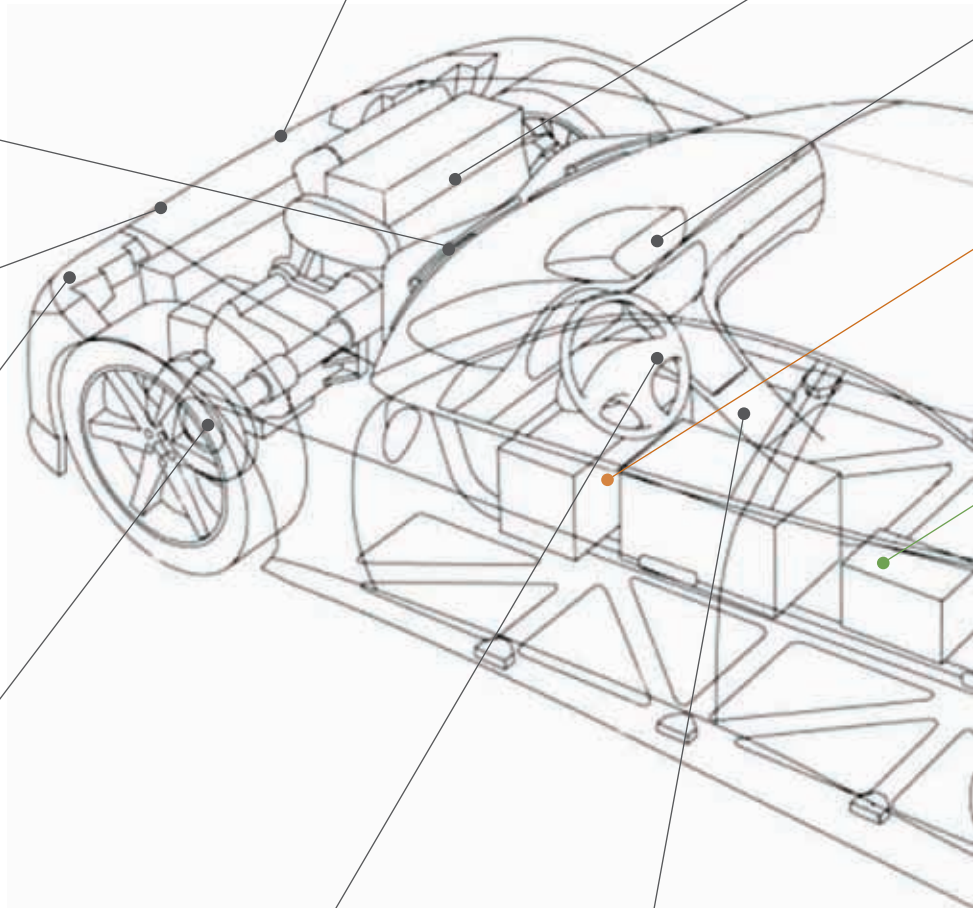

Thermal Mgt System & Cooling Pumps (Engine Detail)



Water Pump

Air Con, Heaters & Dashboard Display



Air Temperature Sensor

Inverters



Opto Isolators for HV Power Management



HV Resistors for Voltage Control

DC-DC Converters



Boost Inductor



Flyback Transformer



Current Sense Resistors



Inrush Current Limiting Resistors



Voltage Converter

Batteries



Battery Pack Heater



Inrush Current Limiting Resistors



Precision Resistors for Voltage Monitoring



Air Temperature sensor



Power Resistors for Load Dump



Battery Ballast Modules



Flyback Transformer Battery Power Management

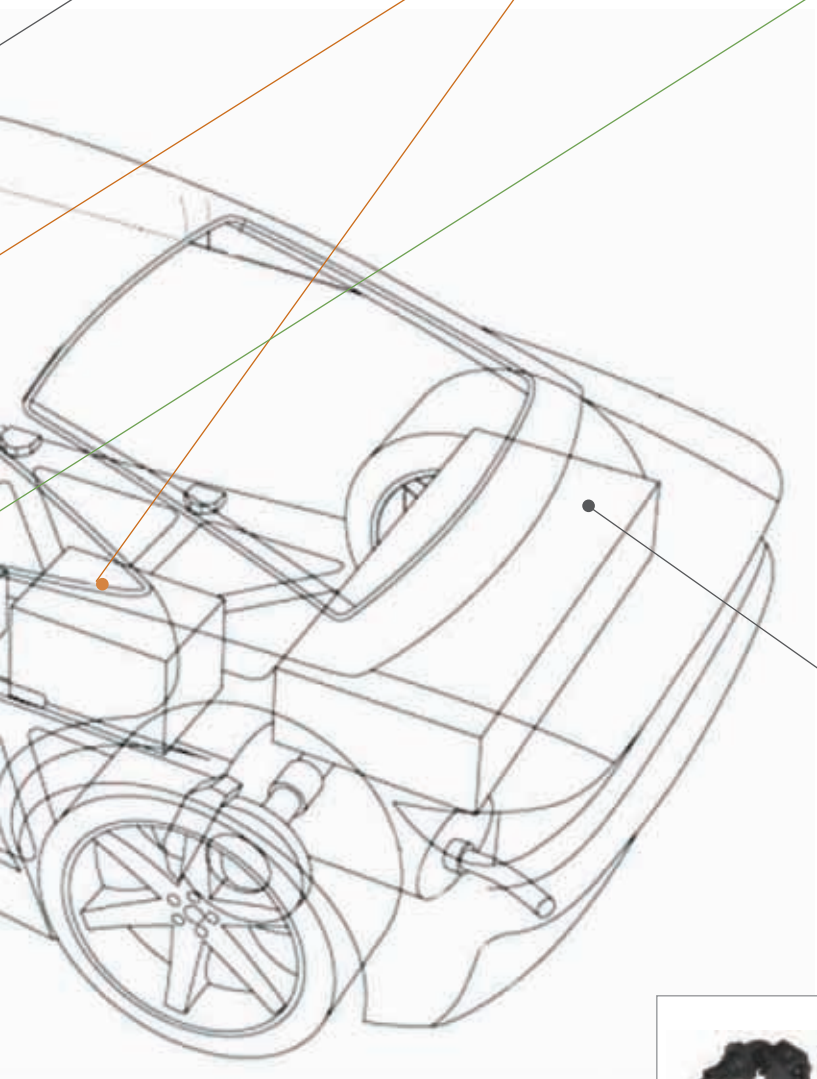

Global Sales Offices



North America

Email: sales@ttelelectronics-na.com

Europe

Email: sales@ttelelectronicseurope.com

Asia

Email: sales@ttelelectronicasia.com