

Platon Gapmeter Type AP

ARMoured PURGE FLOWMETER

INDEX

Introduction	1
Mechanical Specification	2
Installation	3
Maintenance	4
Dimensional - API	4
Drawings - APT	5
- APV	5
- AP Panel Mounting Detail	6
Returns & Warranty	7

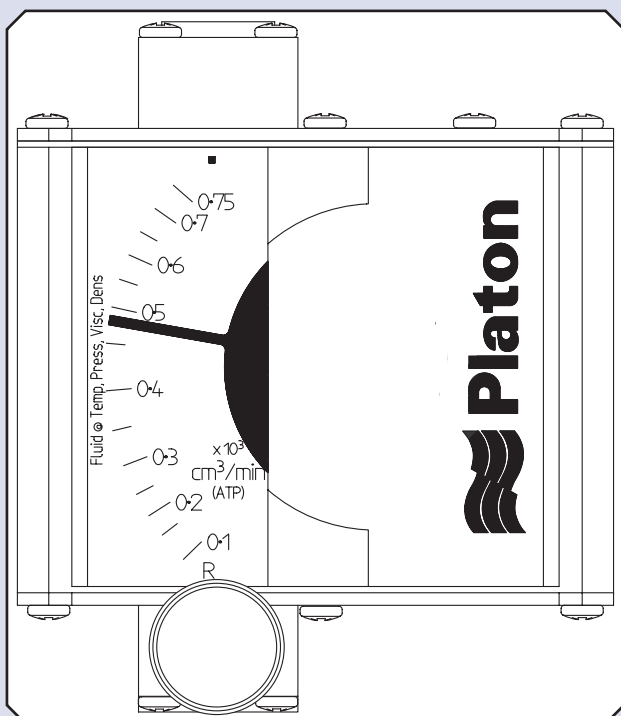

The company policy is one of continuous product improvement and the right is reserved to modify the specifications contained herein without notice.

INTRODUCTION/PRINCIPLE OF OPERATION

Armoured Purge meters type API, APT & APV are direct reading flow meters for liquid or gas measurement on small lines. Using a stainless steel tapered tube to create a Variable Area (VA) flow meter, the magnetically coupled pointer shows flow rate on an external scale.

Armoured purge meters are chosen where the higher integrity offered by a metal tube is important or where glass tubes are not allowed in the process.

Ideal for flow monitoring in purging, mixing or sampling systems, the meters are available with Inline (API) or Rear facing (APT/APV) connections. For fine flow rate adjustment the APV model has a multi-turn needle valve built in. The Scale provided shows the flow rate for the actual process fluid and conditions specified.

The units are suitable for flush mounting behind a control panel, using the kit (AP-PMK) ordered as an optional extra.

The rugged design of these instruments allows for their use in a range of applications including chemical, petrochemical, pharmaceutical and water treatment industries.

The measuring element of the AP flow meter consists of two precision components, a float and a tapered tube. The float position within the internally tapered tube is established when the upward flow forces, are balanced by that of gravity acting upon the float. This position is translated through a magnetic coupling, into a pointer position on the scale.

The instruments are calibrated for the customer's process fluid & conditions. If these change from the original specification, the calibration will be affected. Gas calibration will be affected by changes in temperature and pressure, whilst liquid calibrations will be affected by temperature changes only.

MECHANICAL SPECIFICATION

Body Tube/Needle	-	316 Stainless Steel
End Blocks	-	316 Stainless Steel
Float	-	Liquids - 316 Stainless Steel
	-	Gases - Aluminium Alloy
Seals	-	Viton 'O'-rings, neoprene gasket, silicone window seal, PTFE bush (APV only)
Connections	-	API - Inline, 1/4" NPTF
	-	APT/APV - Rear facing, 1/4" NPTF
Flow Orientation	-	Vertically upwards
Temperature Rating	-	-20 to +150°C
Pressure Rating	-	150 bar g @ 20°C - API, APT
	-	40 bar g @ 20°C - APV
Repeatability	-	0.5% FSD
Accuracy	-	VDE/VDI 3513 Class 4 standard
Housing	-	Black anodised aluminium alloy (BS1490 - LM25M)
	-	Polycarbonate window
	-	Weatherproofed to IP65
Scale	-	70mm, 90° typical scale length
Pointers	-	Black flow rate indicator

Note: All the specifications listed above are for standard configuration instruments only. Consult order acknowledgement for details of any special specifications provided.

INSTALLATION

1. Remove all packaging from the flow meter body.
2. The instrument should be examined for any transit damage prior to installation in the pipe work.
3. The cover should be fitted to exclude ingress of dirt and moisture presence on the indicator mechanics.
4. The upstream & downstream pipe bores should be the same nominal size as the instrument. Straight pipe lengths of five diameters upstream and two diameters downstream should be provided.
5. Ensure the instrument is installed vertically in the pipe work with the direction of flow upwards.
6. Before the meter is installed, the pipeline should be cleared of any foreign matter likely to inhibit the performance of the meter. A 50 micron filter should be fitted upstream of the meter, if particles larger than this might be present in the flow.
7. Ensure that any ferro-magnetic material is clear of the instrument by 100mm minimum.

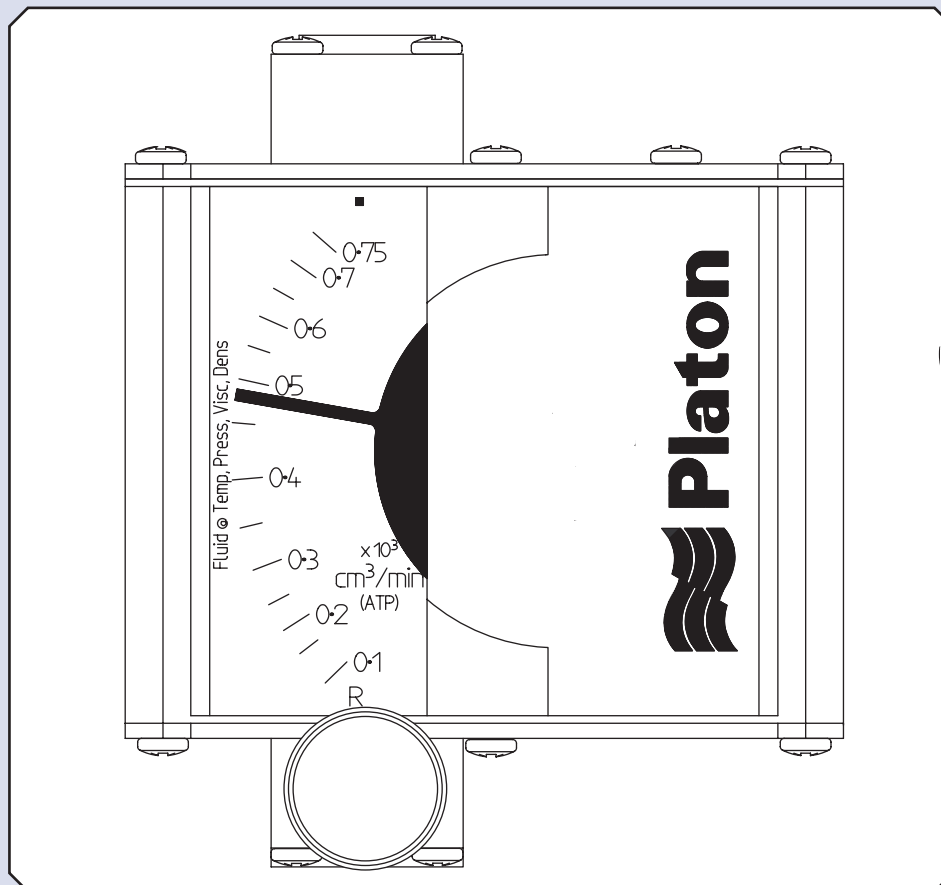

MAINTENANCE

The instrument should not normally require any attention, but if any problems occur check the following:

Firstly ensure the instrument is vertical and when the flow is at zero the pointer is at rest ('R') position. If the pointer is not aligned with the 'R' position do not adjust the pointer before verifying:

- By internally inspecting the flow meter body, check that the float is at rest and is not obstructed by any process debris.
- That the pointer moves over the full scale of 70mm. It is possible to deflect the metering disc by pushing the float with a suitable brass bar or other non-magnetic material.

There should be approximately 20mm movement of float travel for FSD of the needle.

- That the screws securing the end blocks to the indicator are tightened.
- That any ferro-magnetic material is clear of the instrument by 100mm minimum.

Only then should the pointer be adjusted. This is achieved by locating a screw driver in the slot on the top of the pointer and by hand, gently rotating the pointer until it is pointing at the rest ('R') position (See Page 3, Section 8). This adjustment must be carried out with the flow meter in the correct vertical orientation.

API - DIMENSIONAL DRAWING

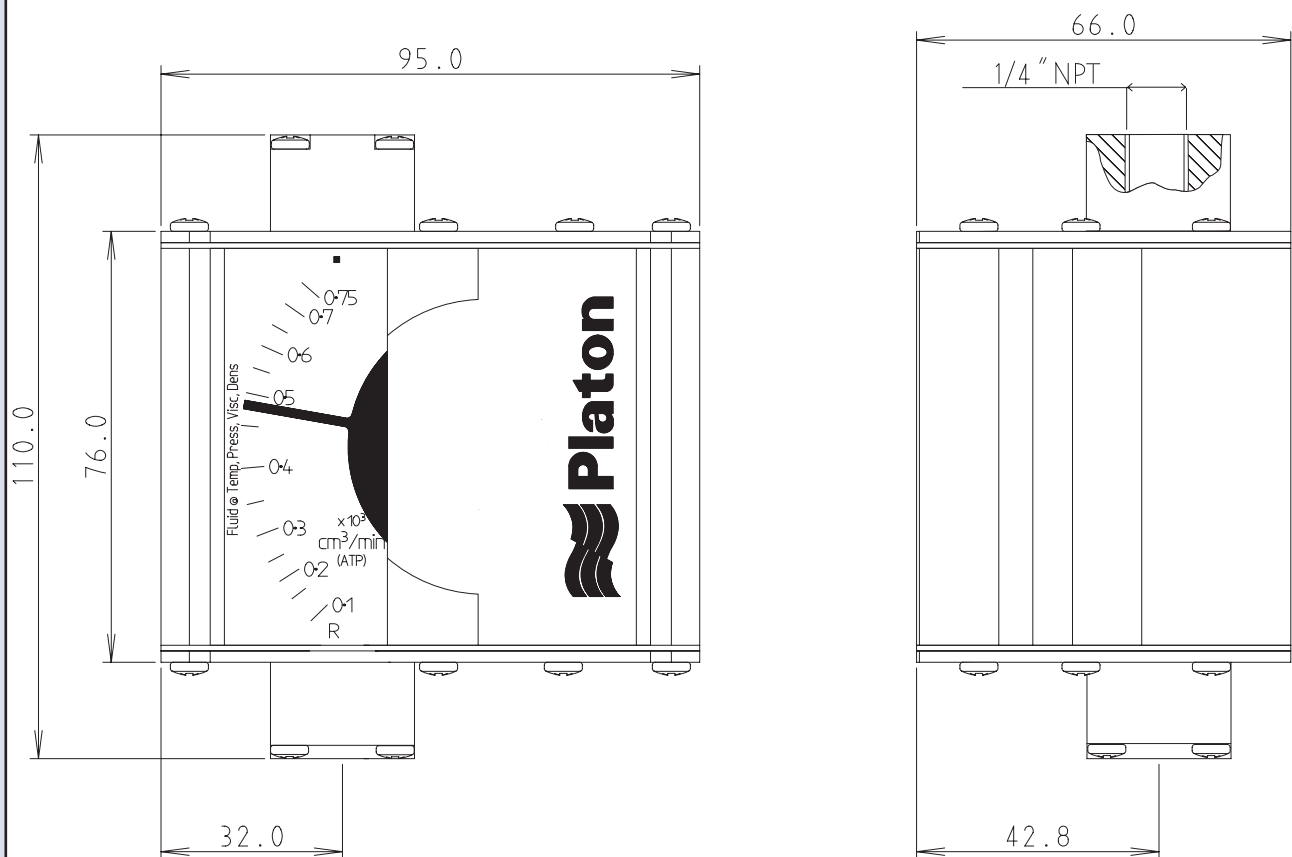

APT - DIMENSIONAL DRAWING

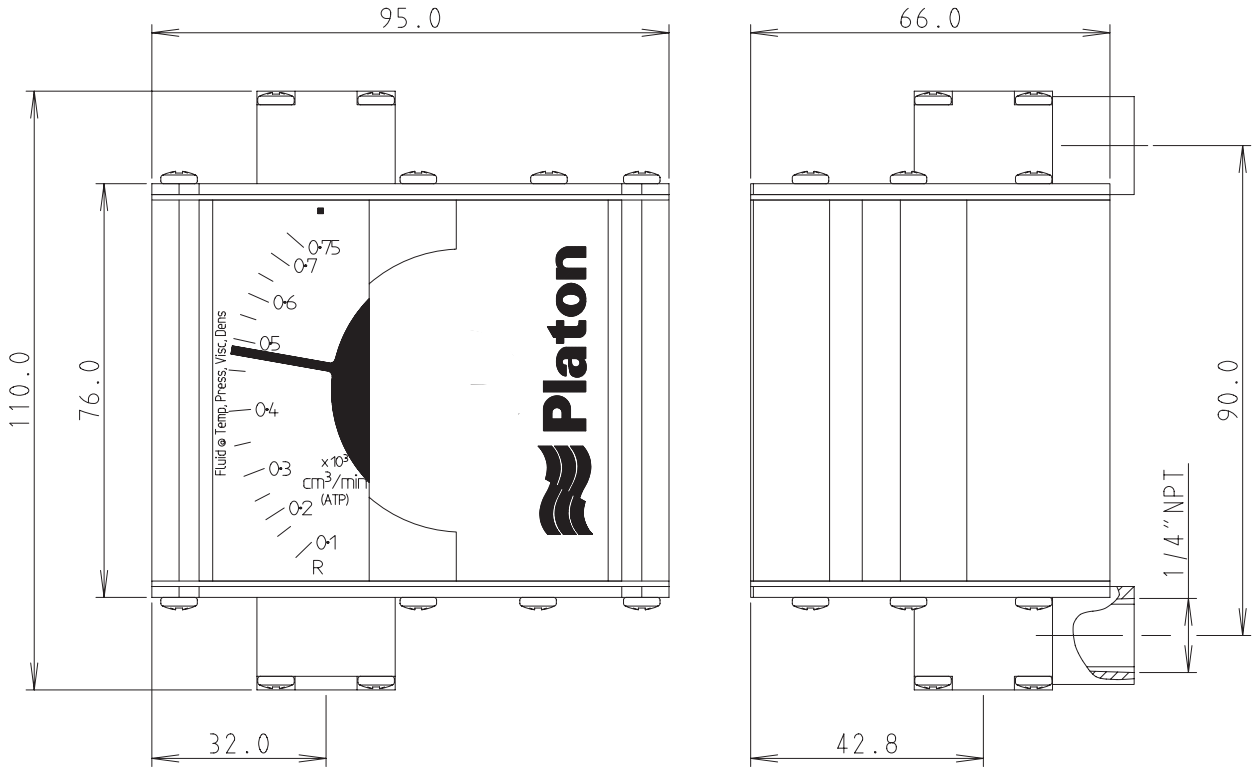

APV - DIMENSIONAL DRAWING

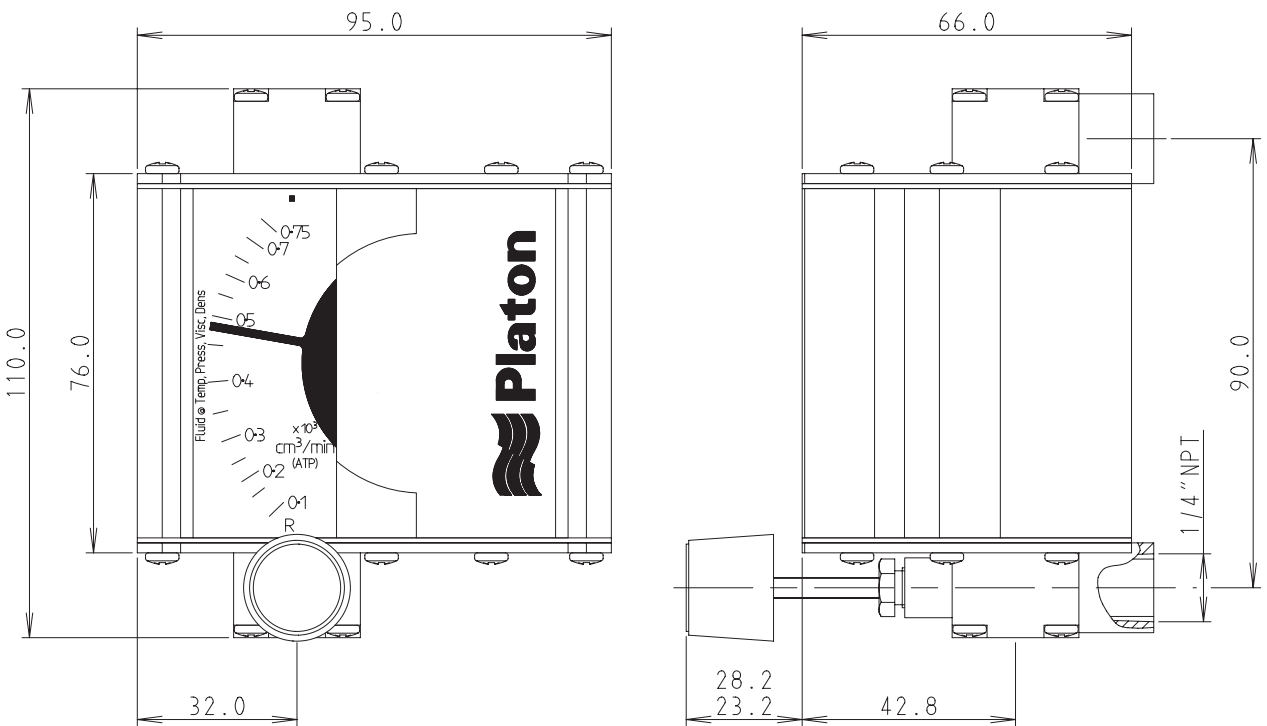

AP PANEL MOUNTING DETAIL DIMENSIONAL DRAWING

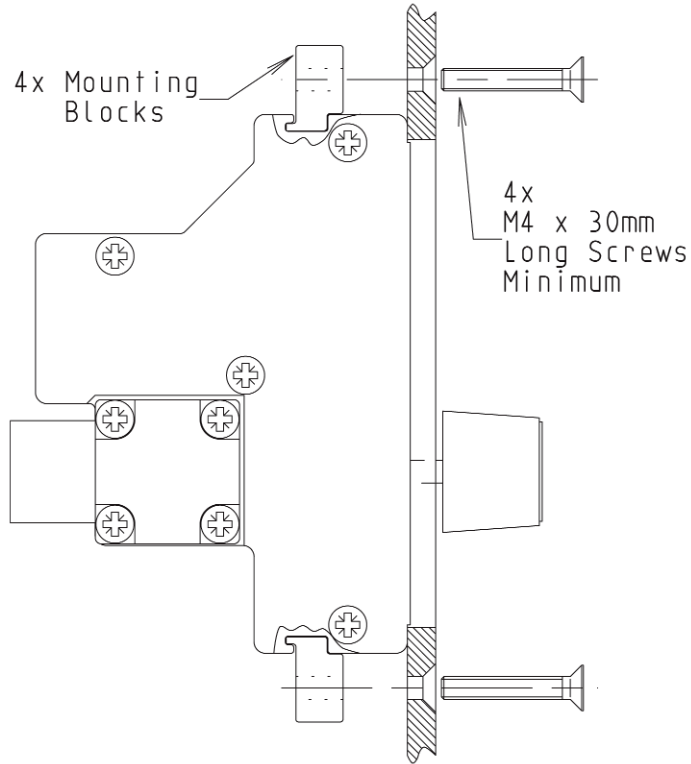

AP PANEL CUT-OUT DETAIL DIMENSIONAL DRAWING

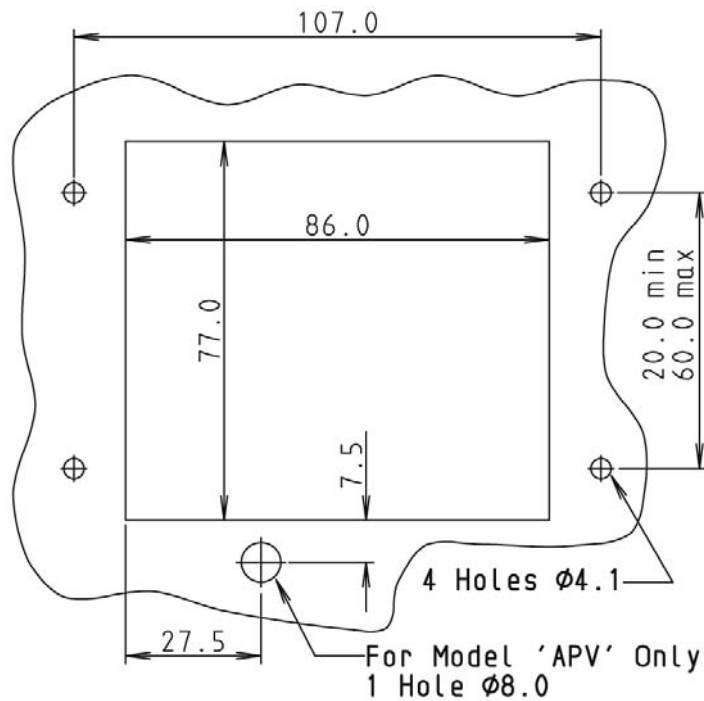

RETURNS & WARRANTY

Before returning any goods to RM&C you must obtain a Returns form containing a unique returns (CA) authorisation number. Failure to do so will result in the goods being returned to you, without any inspection, etc... To obtain this form, contact the Q.A. department of our Sheffield office and by return the form will be faxed to you.

On receipt of the Returns form, fill in any required fields and return it with the goods to the Sheffield office. It is advisable to keep a copy of this form (with authorisation No.) for reference purposes.

If the goods have come in contact with any processes or environments that may be harmful to a user, then COSHH Regulations must also be observed. It is requested that a Material Safety Data Sheet (MSDS) is also supplied with returned goods, if this is likely to be the case. If not provided and the goods are suspected of being contaminated, they will be returned to you.

On receipt of appropriate documentation the goods will be examined & assessed in accordance with the terms of any Warranty agreement.

Repairs

Prior to any repair work being carried out, you will be informed of our findings & any charges that may be incurred.

Replacements

Prior to the supply of any replacements, you will be informed of our findings & any charges that may be incurred.

No replacements will be sent prior to receiving the goods back from you, unless an Order number is supplied to cover the cost of the new unit/s. After inspection, etc.... of the returned goods a Credit may be issued, based on our findings

Warranty (extract from Terms & Conditions)

The warranty period is normally 12 months from the date of shipment, except as agreed at the time of sale.

Any misuse of the goods will void any warranty.

For full Warranty & other Contract details refer to our 'Terms & Conditions'.

Every effort has been made during the preparation of this document to ensure the accuracy of statements and specifications. However, we do not accept liability for damage, injury, loss or expense caused by errors or omissions made. We reserve the right to withdraw or amend products or documentation without notice.

Head Office: 2 Downgate Drive, Sheffield, S4 8BT, England
Tel: +44(0)114 244 2521 Fax: +44(0)114 243 4838



2 Downgate Drive, Sheffield, S4 8BT, England
Tel: +44(0)114 244 2521 Fax: +44(0)114 243 4838
email: sales@roxspur.co.uk www.roxspur.com



CERTIFICATE NO. 22358

07HWAR0910