

Platon Floscan Alarm Type GIR

INFRA-RED FLOW ALARM SENSOR FOR GLASS TUBE VA FLOWMETERS

INTRODUCTION

The Floscan flow alarm sensor type GIR is an infra red sensor module which monitors the passage of a variable area flowmeter float through the sensor, giving an electrical flow alarm output. One or two sensors can be installed on a Platon Flowtube, typically on a NG/NGX or LG/LGX series frame, held in place by a spring clip located in the extrusion profile at the back of the frame. GIR units can also be supplied fitted in GU housings.

The sensor monitors the float movement to remember whether the float is above or below the sensor location - the electronics can only give a reliable output after the first detection of this float movement following power up: it loses the memory on power down.

The sensor is external to the flowmeter cover on NG/NGX and LG/LGX series frames, and requires that the back of the frame is spaced from any panel by approximately 5mm. This is achieved by fitting the threaded spacers (provided) onto the frame mounting studs.

Once fitted, the sensor can be slid up and down to the required position on the flowtube. The normal output is for a low flow alarm, where the cable exits downwards. For a high flow alarm, the sensor can be rotated through 180° with the cable exiting upwards. Note that in this orientation the IP44 rating of the unit will be reduced.

INSPECTION

1. Remove from packaging and check there is no physical damage.
2. Check that the following components are enclosed:
 - 2 x M5 threaded spacers
 - 1 x Spring clip
 - 1 x Sensor module
3. Check that the GIR part number identifies that it has been set up for use on the tube size and fluid to be used. Part numbering is as follows:

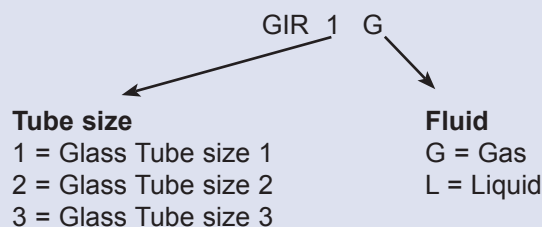

4. Note that GIR modules should only be used with the glass tube supplied with the order. Older glass tubes may have scale markings which interfere with the infra-red transmission paths (see Maintenance and Fault Finding section).

DIMENSIONS AND POSITIONING

Figure 1 - Plan view of GIR sensor fitted to NG/LG flowmeter frame.

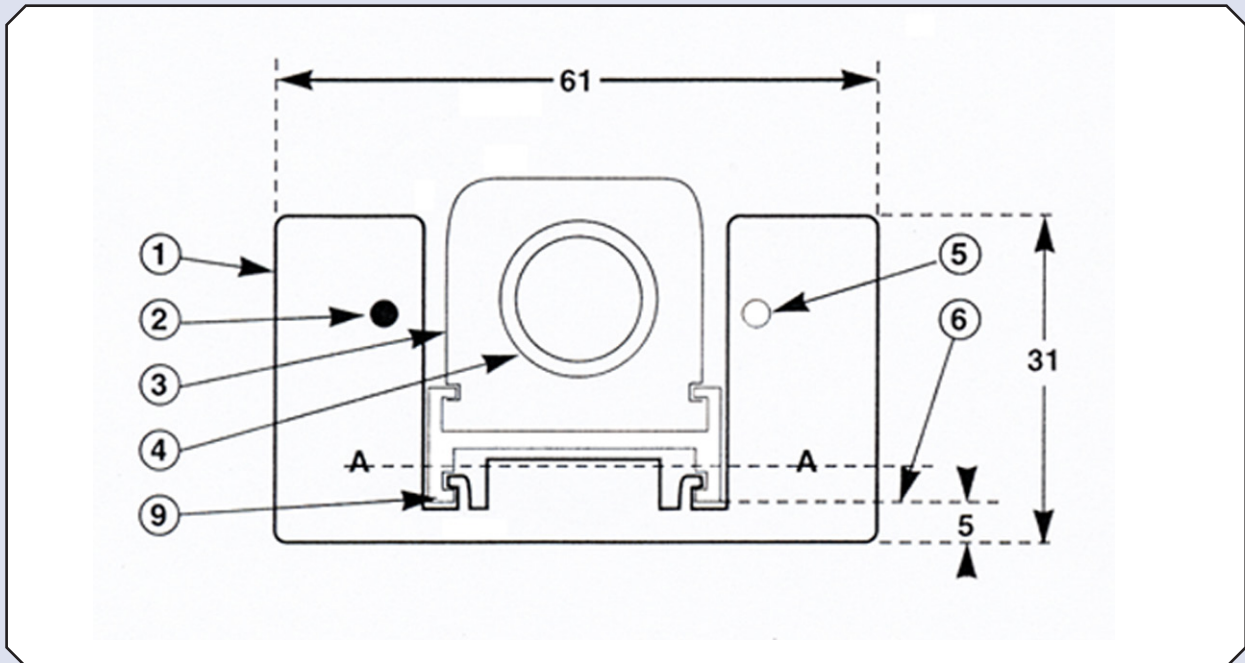

Key for figures 1, 2 and 3

- 1 GIR module housing
- 2 Infra-red transmitter
- 3 NG/NGX or LG/LGX series flowmeter cover
- 4 GTF glass flow tube
- 5 Infra-red receivers (2)
- 6 Plane of back of flowmeter frame
- 7 Spring retaining clip
- 8 Spacer fitted on flowmeter mounting stud to space from a panel
- 9 Flowmeter frame
- 10 GIR external cable
- 11 Safety relief vent (for discharge of fluids should a tube fail)

Figure 2 - Back view on section 'A-A'

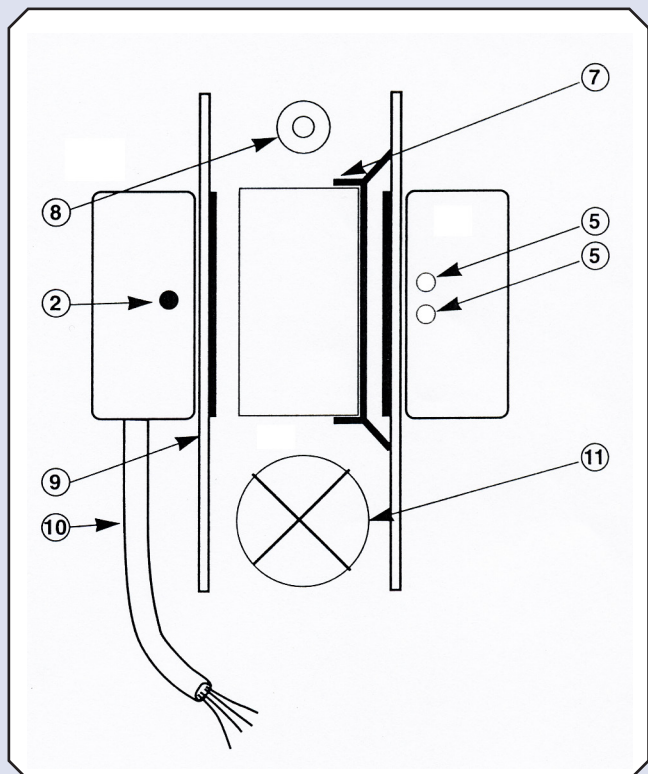
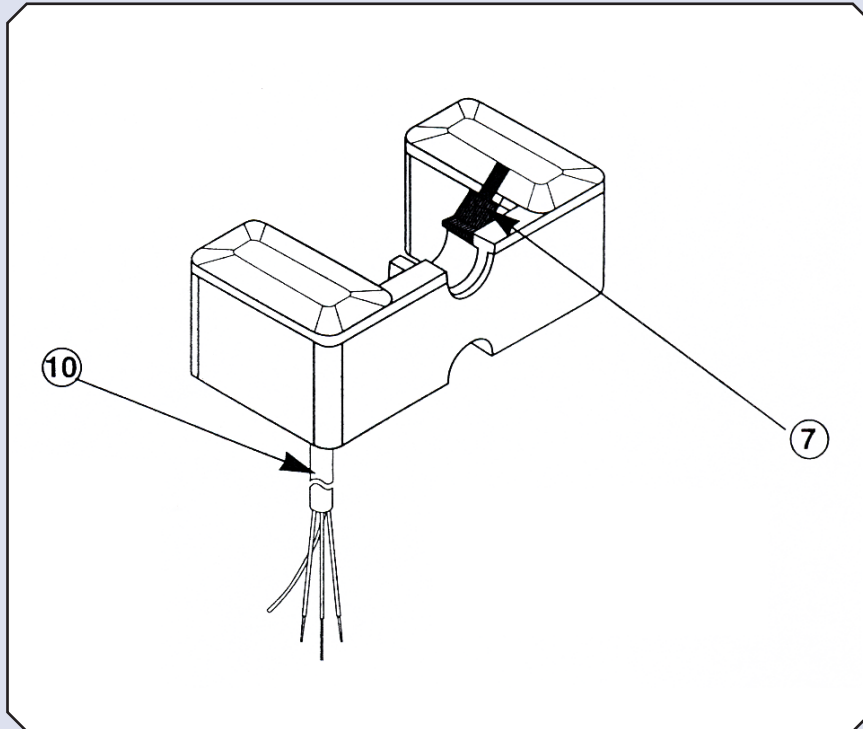

Figure 3 - GIR Module with clip fitted



SENSOR INTERFACE

Normal Low Flow Alarm

The sensor is powered by a d.c. voltage (12/24V nominal) and provides an open collector transistor output capable of switching up to 50mA from a d.c. supply (maximum 30V).

This output is conducting (i.e. a short circuit) for flows higher than the set point, when the cable exits from the base of the GIR sensor once it is mounted on the flowtube. This is typically a low flow alarm, since low flows give a non-conducting or open circuit output.

Interface Module (refer to OMM 1043)

When used with the Floscan alarm mains interface module (58384) the conducting transistor output state described above will energise the Floscan alarm relay and light the front panel green LED. This is therefore a failsafe low flow alarm, since power or cable failure will cause the relay to revert to the "alarm" state.

High Flow Alarm

If it is required that the conducting transistor state should occur at low flows, and that high flow conditions should give an open circuit/no current alarm, the GIR sensor module can be inverted on the flowmeter frame. In this new orientation, the cable will exit from the top face of the sensor module. Note that in this orientation the IP44 rating of the unit will be reduced.

INSTALLATION

Orientation

Decide whether to mount the sensor in its normal orientation, or reversed (see Sensor Interface section) for the required output signal.

Panel Mounting

The flowmeter frame can be mounted on a vertical panel if required, with the alarm sensor still fitted and adjustable. To achieve this, it will be necessary to space the flowmeter frame from the panel face by at least 5mm: spacers are provided to fit to the mounting studs. It will be necessary to fit the sensor to the flowmeter frame before installing the flowmeter against the panel. The maximum panel thickness is reduced compared to the normal NG/NGX/LG/LGX flowmeter, because of the spacing away from the surface. Typically, the maximum panel thickness possible with an alarm is 4mm.

Installation

The sensor has been tested and adjusted to perform best with the spring retaining clip mounted on the opposite side of the flowmeter frame to the cable exit from the sensor. It is easiest to install the spring clip and sensor with the flowmeter face down, in a horizontal plane. The spring clip and sensor are fitted separately - they are not glued together in any way.

1. Place the spring clip inside the back of the flowmeter frame, with the two smallest (angled) projections located in the groove in the extrusion (see Figure 2).
2. Place the sensor module, with the sensor lobes downwards to the front of the flowmeter, over the spring clip.
3. By tipping the flowmeter to make the spring clip stay in the extrusion groove, the sensor central block can be located behind the flat part of the spring clip. Gentle pressure will then need to be applied on the centre back of the sensor to press the "ears" on the moulding past the outer lip of the back of the flowmeter frame. The sensor will then be held in place.

4. If it is necessary to release the sensor, the "ears" have to be forced back over these edges. This is easier to achieve from the bottom edge of the sensor (the edge where the cable exits) - lifting this edge first.
5. The flowmeter can be returned to the vertical and the sensor moved along the extrusion to the required switch point. The nominal switch point is located on the centre line of the sensor lobes. This will give the correct low flow alarm switch point.

The high flow alarm switch point occurs when the bottom of the float is at the centre line of the alarm sensor lobes. The sensor therefore needs to be positioned with its centre line below the required set point, by a distance corresponding to the float length.

ELECTRICAL CONNECTIONS

(Refer to Figure 4)

● RED WIRE (+V)

This is the d.c. power supply to the sensor circuit.

Connect to a d.c. supply between 8V and 26V (positive with respect to the common terminal).

Nominal current drawn is 25mA.

● WHITE WIRE (O/P)

This is the "output" or "signal" connection.

It is from an "open collector" type output.

The source transistor can be used to switch up to 50mA from up to a 30V d.c. positive supply with respect to the common terminal.

● BLACK WIRE (Common)

This is the common return line for the power supply and the output signal.

This would typically be referred to as "0 Volts".

● CABLE SCREEN

This should be connected to earth to provide the shielding required for EMC protection.

Figure 4 - Electrical Connections

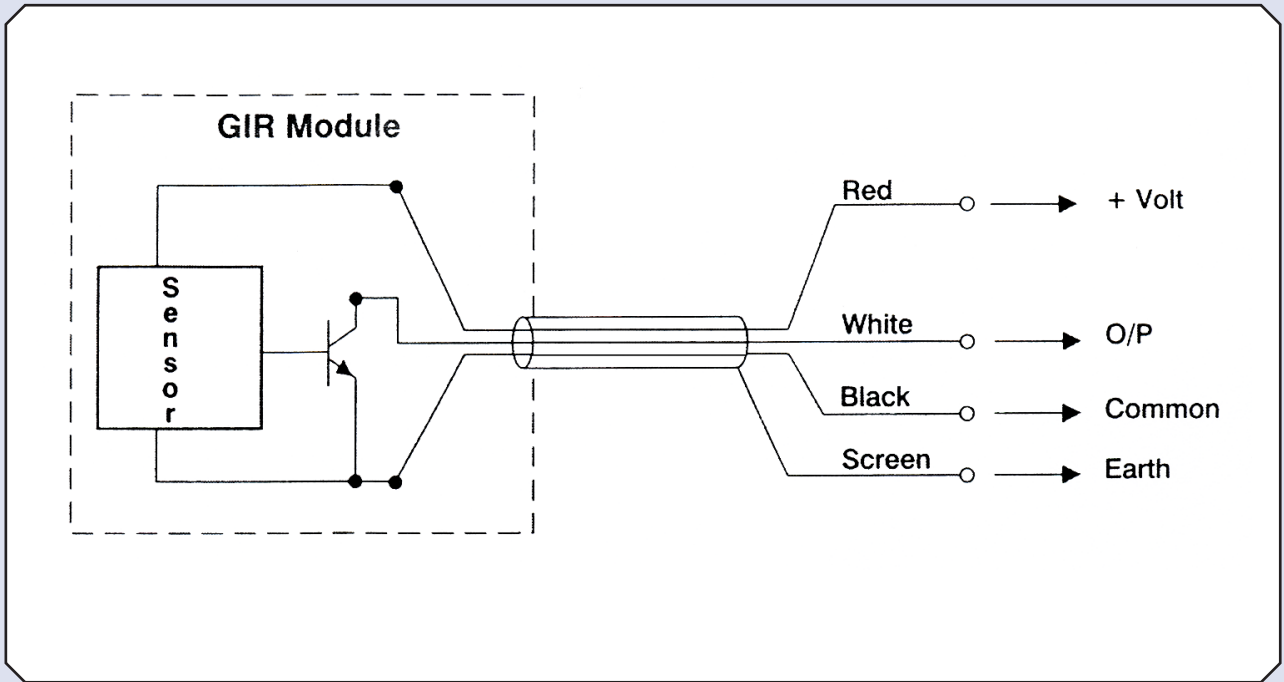
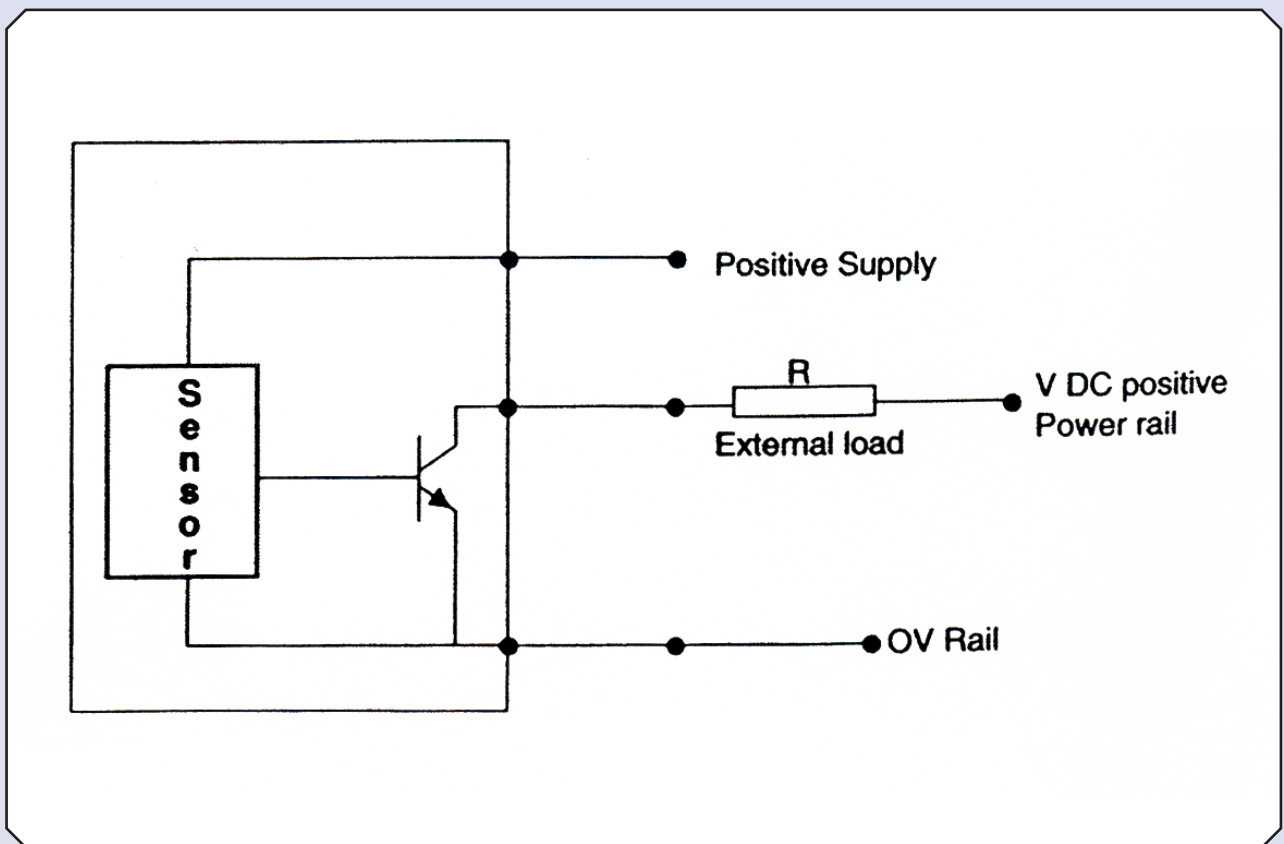

Figure 5 - External Load Connections



OUTPUT PROTECTION

Ex-factory Protection

The load connected to the output cable from a suitable d.c. supply must be sufficient to limit the current drawn to below 50mA. Currents exceeding 50mA through the transistor will cause damage - the transistor will fail and the warranty will be invalidated.

Load Calculation

The external circuit must be configured as per Figure 5.

Minimum load, $R = V/50\text{mA}$

For a typical power rail of 24V, this calculation shows that the load resistance, R should be 480 Ω minimum.

MAINTENANCE & FAULT FINDING

Maintenance

Regular maintenance can be described as:

1. Check that the sides of the flowmeter polycarbonate cover are clean and scratch free (inside & outside).
2. Check that the glass flowtube is clean (inside & outside) and positioned with the scale markings at the front of the meter.
3. Check that the GIR sensor is properly clipped to the flowmeter frame, to switch at the correct flow rate, and that the internal faces of the sensor are clean. If fitted, the attenuation label should be stuck in place over the receiver face.
4. Only clean with a cloth dampened with water so as to avoid electrostatic risk.
5. There are no user serviceable parts.

Fault Finding

1. Check the sensor is correctly fitted and that the flowtube has the scale towards the front of the meter.
2. Clean the flowmeter cover.
3. Check that the glass flow tube has not been replaced with an older spare. Older GTF tubes size 1 & 2 had scale markings which could interfere with the GIR sensor: suitable new tubes have scale codes starting with letter C, such as CA141002. Codes starting B or 1 are not suitable.
4. Check that the GIR part number corresponds to the float and fluid in use - this determines the attenuator label type which is fitted on the GIR receiver face. Ensure that the label is undamaged and stuck in place.
5. Remove any bright source of light (which might have an infra-red component) which could saturate the receiver amplifiers. For example, 75 Watt filament bulbs must not be closer than 1m to the flowmeter. A light shield (42532) can be purchased to help with this but it will obscure the scale at the alarm set point.
6. Check the external load in the output circuit. Shorting of this load would damage the output transistor.
7. Check the power supply connections.
8. Check the output cable for visible damage or kinking, which could have broken the conductors.
9. Simulate float movement past the sensor using a strip of paper or card, between the sensor and flowmeter cover.
10. No repair is possible on the sensor electronics, so a faulty unit can only be replaced completely.

HAZARDOUS AREA INSTALLATION

The GIR sensor is approved intrinsically safe to EEx ia IIC T4, a copy of the EC Type Examination certificate is attached, Sira 03ATEX2401X.

When used in a hazardous area, the GIR sensor should be used with a 12V d.c. supply, protected by a 15V 100Ω shunt diode safety barrier as per Figure 6. Because the GIR module requires 8V and 25mA for correct operation, the barrier chosen must have end to end resistance below 160Ω. A suitable barrier is the MTL 767, with 155Ω resistance.

The Floscan mains relay module (Platon part 58384), can still be used to provide a control room interface, on the safe side of the zener barrier.

Install the equipment following Figure 6 and the associated notes.

Aggressive Substances

If the equipment is likely to come into contact with aggressive substances, then it is the responsibility of the user to take suitable precautions that prevent it from being adversely affected, thus ensuring that the type of protection is not compromised.

Aggressive substances	- e.g. acidic liquids or gases that may attack metals, or solvents that may affect polymeric materials
Suitable precautions	- e.g. regular checks as part of routine inspections or es-tablishing from the material's data sheet that it is resistant to specific chemicals

SPECIAL CONDITIONS FOR SAFE USE

The certificate number has an 'X' suffix, which indicates that special conditions of installation and use apply. Those installing or inspecting this equipment must have access to the contents of the certificate.

The following special condition of certification applies:

Parts of the enclosure are non-conducting and may generate an ignition-capable level of electrostatic charge under certain extreme conditions. The user should ensure that the equipment is not installed or used in a location where it may be subjected to external conditions (such as high-pressure steam) which might cause a build-up of electrostatic charge on non-conducting surfaces. Additionally, cleaning of the equipment should be done only with a cloth dampened with water.

Safety Related Devices

The equipment has not been assessed as a safety device as defined by the ATEX directive 94/9/EC.

Other Information

-  II 1G, EEx ia IIC T4, Sira 03ATEX2401X
- The equipment may be used with flammable gases and vapours with apparatus groups IIA, IIB and IIC and with temperature classes T1, T2, T3 and T4
- The equipment is only certified for use in ambient temperatures in the range -20°C to +40°C and should not be used outside this range
- The GIR Flow Alarm Sensor is intended to be used in areas that are protected from wind blown dust and rain
- For manuals in other EU languages, please contact: sales@roxspur.com



1 **EC TYPE-EXAMINATION CERTIFICATE**

2 Equipment intended for use in Potentially Explosive Atmospheres Directive 94/9/EC

3 Certificate Number: Sira 03ATEX2401X

4 Equipment: GIR Flow Alarm Sensor

5 Applicant: Roxspur Measurement & Control Ltd (Platon)

6 Address: 2 Downgate Drive
Sheffield
South Yorkshire
S4 8BT
UK

7 This equipment and any acceptable variation thereto is specified in the schedule to this certificate and the documents therein referred to.

8 Sira Certification Service, notified body number 0518 in accordance with Article 9 of Directive 94/9/EC of 23 March 1994, certifies that this equipment has been found to comply with the Essential Health and Safety Requirements relating to the design and construction of equipment intended for use in potentially explosive atmospheres given in Annex II to the Directive.

The examination and test results are recorded in confidential report number R52A9357B.

9 Compliance with the Essential Health and Safety Requirements, with the exception of those listed in the schedule to this certificate, has been assured by compliance with the following documents:

EN 50014:1997 (amendments A1 to A2)

EN 50020:2002

EN 500284:1999

10 If the sign 'X' is placed after the certificate number, it indicates that the equipment is subject to special conditions for safe use specified in the schedule to this certificate.

11 This EC type-examination certificate relates only to the design and construction of the specified equipment. If applicable, further requirements of this Directive apply to the manufacture and supply of this equipment.

12 The marking of the equipment shall include the following:



II 1G

EEx ia IIC T4 (Ta = -20°C to +40°C)

M D Shearman
Certification Manager

Project Number 52A9357
Date 27 August 2003
C. Index 12

This certificate and its schedules may only be reproduced in its entirety and without change

Sira Certification Service

Rake Lane, Eccleston, Chester, CH4 9JN, England
Tel: +44 (0) 1244 670900 Fax: +44 (0) 1244 681330
Email: exhazard@siratc.co.uk

Page 1 of 2

Sira Certification Service is a service of Sira Test & Certification Ltd

ST&C(Chester) Form 9176 Issue 7



SCHEDULE

EC TYPE-EXAMINATION CERTIFICATE

Sira 03ATEX2401X

13 DESCRIPTION OF EQUIPMENT

The type GIR Flow Alarm Sensor is a sensor module that monitors the passage of a variable area flowmeter float through the sensor giving an electrical flow alarm output. The equipment is fitted with a flying lead and comprises two printed circuit boards mounted in a plastic case.

The type GIR Flow Alarm Sensor is intended to be used in areas that are protected from wind blown dust and rain and has the safety description detailed below:

Ui = 16 V
Ii = 300 mA
Pi = 1.14 W
Ci = 133.1 nF
Li = 0

14 DESCRIPTIVE DOCUMENTS

14.1	Drawing	Sheet	Rev.	Date	Title
	1-G996	1 of 1	3	13 Aug 03	I.S. GIR Alarm Module
	376036	1 of 1	3	15 Sep 95	GIR Emitter PCB Copper Layouts
	376037	1 of 1	2	29 Aug 95	GIR Receiver PCB Copper Layouts
	376654	1 of 1	3	15 Sep 95	NG/LG Alarm Circuit Diagram
	4-M338/-	1 of 1	3	13 Aug 03	GIR Alarm Module Serial No. Label
	4-M345	1 of 1	2	13 Aug 03	GIR Alarm Module I.S. Code Label
	4-M346	1 of 1	2	13 Aug 03	GIR Alarm Module Warning Label

14.2 Report No. R52A9357B

15 SPECIAL CONDITIONS FOR SAFE USE (denoted by X after the certificate number)

15.1 Parts of the enclosure are non-conducting and may generate an ignition-capable level of electrostatic charge under certain extreme conditions. The user should ensure that the equipment is not installed or used in a location where it may be subjected to external conditions (such as high-pressure steam) which might cause a build-up of electrostatic charge on non-conducting surfaces. Additionally, the equipment shall only be cleaned with a damp cloth.

16 ESSENTIAL HEALTH AND SAFETY REQUIREMENTS OF ANNEX II (EHSRs)

The relevant EHSRs that are not addressed by the standards listed in this certificate have been identified and individually assessed in Report No. R52A9357B.

17 CONDITIONS OF CERTIFICATION

17.1 The use of this certificate is subject to the Regulations Applicable to Holders of Sira Certificates.

17.2 Holders of EC type-examination certificates are required to comply with the production control requirements defined in Article 8 of directive 94/9/EC.

Date 27 August 2003

This certificate and its schedules may only be reproduced in its entirety and without change

Sira Certification Service

Rake Lane, Ecclestone, Chester, CH4 9JN, England
Tel: +44 (0) 1244 670900 Fax: +44 (0) 1244 681330
Email: exhazard@siratc.co.uk

Sira Certification Service is a service of Sira Test & Certification Ltd

Page 2 of 2

ST&C(Chester) Form 9176 Issue 7

Figure 6 - Intrinsically Safe Installation (2-W142)

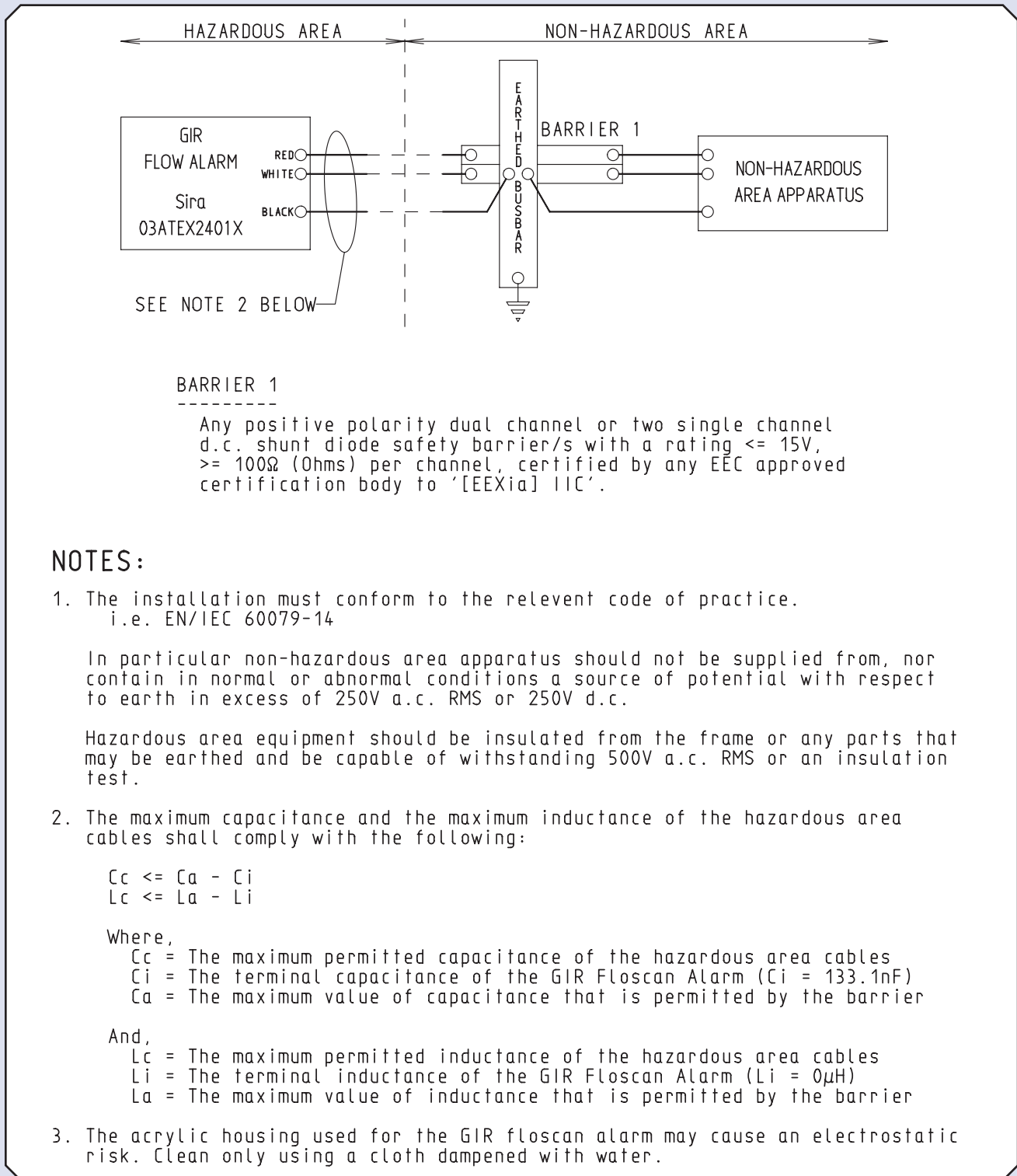

Every effort has been made during the preparation of this document to ensure the accuracy of statements and specifications. However, we do not accept liability for damage, injury, loss or expense caused by errors or omissions made. We reserve the right to withdraw or amend products or documentation without notice.

Head Office: 2 Downgate Drive, Sheffield, S4 8BT, England
Tel: +44(0)114 244 2521 Fax: +44(0)114 243 4838



2 Downgate Drive, Sheffield, South Yorkshire, S4 8BT
Tel: +44(0)114 244 2521 Fax: +44(0)114 243 4838
email: sales@roxspur.com www.roxspur.com



CERTIFICATE NO. 22358

07HWAR0910