

Platon Metal Tube VA Gas or Liquid



DS1220

Features:

- ½" - 4" line sizes
- No power required
- Clearly visible meter
- Scaled for process fluids
- Easy installation—flanged or screwed
- No glands or seals
- Robust, simple construction
- Pulsation damper on gas meter

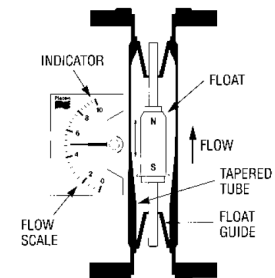

PLATON METAL TUBE VA FLOWMETER TYPE GMT

GMT metal tube flowmeters are variable area meters of totally welded stainless steel construction. Liquid or Gas flowing up the tapered flowtube lifts the float to an equilibrium position, dependent on flow rate, and a magnetically coupled pointer indicates this flow on an external scale. The large meter indication is easily visible at a distance, with the pointer moving over a 1500 scale. Each scale is produced specifically for the fluid involved and process conditions expected: several flow ranges are available for meters of each standard line size. All gas flow meters are supplied with an integral piston damper to smooth out flow pulsations.

Installation is simple, in a vertical section of flow line: meters can be supplied with EN, ANSI or other standard flanges, or BSP or NPT screwed connections.

The robust construction with no glands or seals to leak means the meters are suitable for high pressure applications, or extremes of temperature. The standard GMT is totally self contained and needs no external power.

Alternative materials are available to special order -for example Hastelloy or Monel wetted parts. For lower cost, Brass or Stainless steel bodied meters 1"-2" in size are available with screwed connections. The indicator can be provided with one or two flow alarm sensors, adjustable over the meter operating range. Full electronic transmission and totalization is also available, using the "VAMPIRE" electronic module.

Metal tube meters are ideal for arduous industrial service as an alternative to large glass tube flowmeters. They have particular advantages, where fluids are opaque or staining, or to provide higher safety and security for dangerous or toxic fluids.

PRINCIPLE OF OPERATION

The metering element consists of a precision machined tapered tube and a float. The height to which the float rises in taper is determined by the gap at which upward flow force and float weight are balanced.

A permanent magnet encapsulated within the stainless steel float drives the external magnetically coupled pointer. Float movement is related to flow rate, and the indicator scale is marked in the correct units of flow for the process conditions.

The standard unit requires no electrical power. Because the measuring element is a sharp edged disc, the meter is relatively insensitive to viscosity changes in the fluid, and to pipe bends in the external pipework. The only moving part in the flow is the float, which is retained in place by float guides at either end of the meter.

General Note

TT Electronics reserves the right to make changes in product specification without notice or liability. All information is subject to TT Electronics' own data and is considered accurate at time of going to print.

TT Electronics | Roxspur Measurement & Control Ltd
2 Downgate Drive, Sheffield, S4 8BT, England | Ph: +44(0)114 244 2521
www.roxspur.com | sales@roxspur.com

Platon Metal Tube VA Gas or Liquid



DS1220

SPECIFICATION

Flanged flow tube	316 Stainless Steel, all welded construction
Flanges	EN1092-1 PN16 or ANSI 150 standard. Other flanges to order
Line Sizes	15, 25, 50, 80, 100mm
Pressure	To flange rating, 100 bar max
Screwed flow tube	Brass or 316 Stainless Steel
Connections	½", 1" or 2" BSPP or NPT standard
Pressure	75 bar max GMTB (Brass) 100 bar max GMTS (Stainless)
Float	316 Stainless Steel PVC float on low pressure drop option units
Pulsation Damper	All gas flowmeters have a dashpot damper built-in

Indicator housing	Polyester coated aluminum alloy, with UV stable polycarbonate face
Protection	IP65
Scale length	Typically 100mm, 150 degrees
Scales	Produced to order to suit process fluid and conditions. Air and water flow ranges quoted opposite
Turndown	Typically 10:1
Accuracy	±2% FSD
Hysteresis	±0.5% FSD
Fluid Temperature	200°C max (higher to special order)
Response time	Less than 0.5 secs
Flow direction	Vertically upwards
Surface finish	1.6µm

ORDER CODE

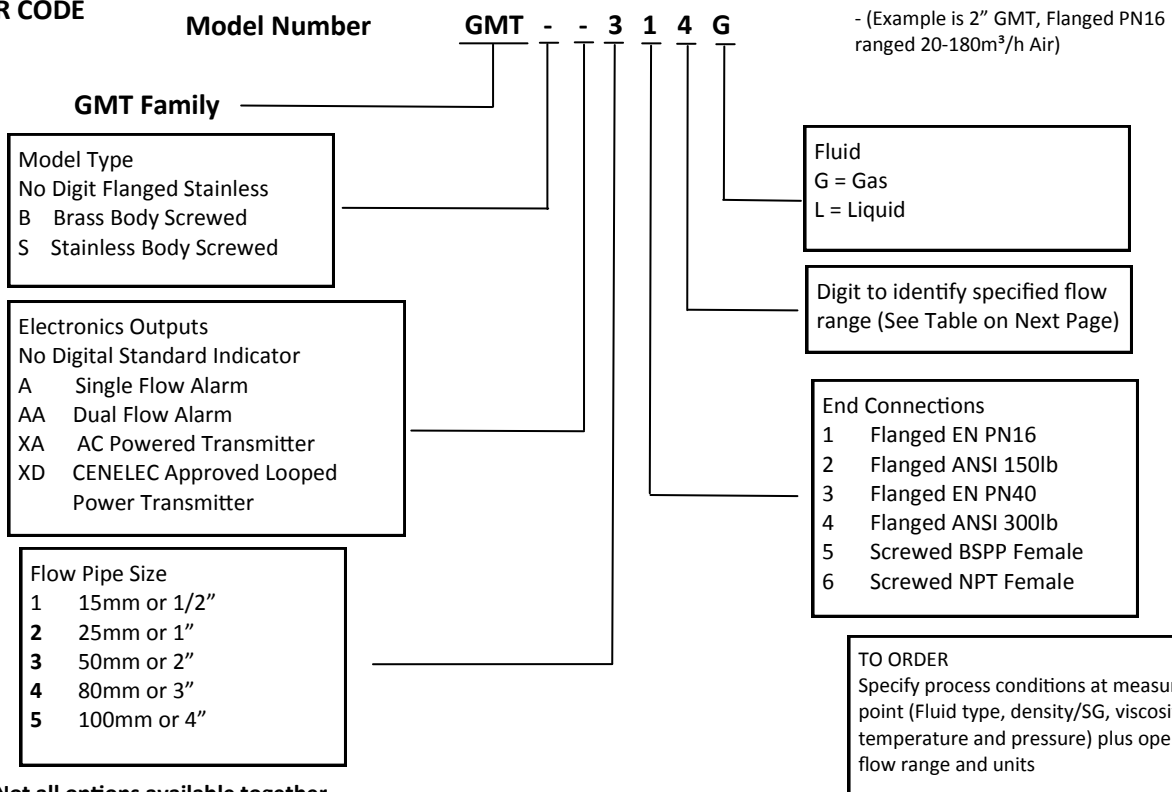

Note: Not all options available together

General Note

TT Electronics reserves the right to make changes in product specification without notice or liability. All information is subject to TT Electronics' own data and is considered accurate at time of going to print.

TT Electronics | Roxspur Measurement & Control Ltd
2 Downgate Drive, Sheffield, S4 8BT, England | Ph: +44(0)114 244 2521
www.roxspur.com | sales@roxspur.com

Platon Metal Tube VA Gas or Liquid



DS1220

FLOW RANGES

Size/Model	Flow Digit	STANDARD UNITS			LOW DP GAS UNITS			
		Water (20°C)	Air at ATP (m ³ /hr)	Max DP (mbar)	Flow Digits	Air (ATP) m ³ /hr	Natural Gas (ATP) m ³ /hr	Max DP (mbar)
15mm (GMT1)	1	20-160 l/h	0.5-5.0	15	A	0.3-3	0.4-3.5	7
	2	20-250 l/h	0.5-7.5	30	B	0.4-4	0.5-5	10
	3	40-400 l/h	1.2-12	20	C	0.5-7	1.0-9	7
	4	60-600 l/h	2.0-18	35	D	1.0-9	1.0-12	10
25mm (GMT2)	1	0.1-1.0 m ³ /h	3.0-30	15	A	1.5-15	2-20	8
	2	0.2-1.6 m ³ /h	4.0-50	30	B	3-23	4-30	9
	3	0.2-2.5 m ³ /h	10-75	35	C	4-36	5-45	8
	4	0.4-4.0 m ³ /h	12-120	80	D	5-50	6-60	9
	5	0.6-6.0 m ³ /h	20-200	160				
	6	1.0-10.0 m ³ /h	30-360	400				
50mm (GMT3)	1	0.6-6.0 m ³ /h	20-180	30	NOTES 1. Unites will be scaled and calibrated for customers specific process conditions, which may differ from those tabulated (see over-leaf). 2. Typical maximum liquid viscosity is 50cP, lower for the highest flow ranges and small sizes. 3. Screwed 1? Units are not available for Flow Digit 6.			
	2	1.0-10.0 m ³ /h	30-300	40				
	3	2.0-16.0 m ³ /h	60-600	80				
	4	2.0-25.0 m ³ /h	100-1000	190				
80mm (GMT4)	1	2.0-2.5 m ³ /h	N/A	140				
	2	3.0-40 m ³ /h	N/A	220				
	3	6.0-60 m ³ /h	N/A	525				
100mm (GMT5)	1	10-100 m ³ /h	N/A	440				

OPTIONS

- Oxygen Service**
Standard units cleaned to required specifications.
Special units available with Brass internal construction
- Alarm Output**
Sensor NAMUR type SJ2-N to DIN 19234
Approval EEx ia LLC T6
Single or dual alarms can be fitted to a GMT flowmeter: The sensor requires a suitable control room interface. Please ask for suppliers separate data sheet.
- Electrical Output**
All GMT flow tube sensors can be fitted with "VAMPIRE" micro based electronics transmitter and flow indicator units. Please see Data Sheet DS1225.
- Alternative body Materials/Design**
PTFE lined meter available for use with corrosive chemical. Float, guides and Flange raised face are PTFE or ceramic.



Refer to DS1221 for screwed GMT data sheet

The hygienic option with crevice free construction is polished to 0.4 - 0.8 µm finish and fitted with Triclover connections. In addition Triclover, RJT, DIN 11851, SMS connections can be fitted to standard flanged body.

General Note
TT Electronics reserves the right to make changes in product specification without notice or liability. All information is subject to TT Electronics' own data and is considered accurate at time of going to print.

TT Electronics | Roxspur Measurement & Control Ltd
2 Downgate Drive, Sheffield, S4 8BT, England | Ph: +44(0)114 244 2521
www.roxspur.com | sales@roxspur.com

Platon Metal Tube VA Gas or Liquid



DS1220

ALTERNATIVE FLUIDS

Approximate flow ranges for alternative process fluids and gas pressures can be calculated using the following formulae. For a full calculation please contact our Sales Team.

1. Gases at pressure or temperature

For air or gas flows where the pressure in the line on the discharge side of the flowmeter is not atmospheric (1.013 bar), multiply the flow range at ATP quoted in the table by a factor calculated as the square root of the pressure (in bar abs) divided by 1.013.

$$\text{Air flow in process} = \sqrt{\frac{P \text{ (abs)}}{1.013}} \times \text{Air flow in table}$$

$$\text{For temperature changes: Air flow at T} = \sqrt{\frac{293}{T \text{ (K)}}} \times \text{Air flow in table}$$

2. Alternative gases

For gases other than air, find the Relative Density (RD) of the gas compared to air, and divide the flow range quoted for air in the table by the square root of the Relative Density.

$$\text{Gas flow range} = \text{Air flow in table} \times \sqrt{\frac{1}{RD}}$$

Examples of RD figures for some gases are as follows

Acetylene	0.898	Carbon Dioxide	1.520	Nitrogen	0.968
Argon	1.380	Hydrogen	0.070	Oxygen	1.105
Butane	2.007	Natural Gas	0.608	Propane	1.522

3. Alternative liquids

For non-viscous liquids other than water, the main correction arises from the density/SG. For the process liquid flow range, multiply the water flow range from the table by a factor D from below.

SG	0.6	0.7	0.8	0.9	1.0	1.1	1.2	1.3	1.4
D	1.328	1.221	1.134	1.062	1.000	0.947	0.900	0.858	0.821

For liquid of 1.2 SG, the GMT411L flowmeter would have a full scale flow of 25 x 0.9 i.e 22m³/hr: the scale would be drawn 2-23 typically. Actual scale used would be rounded up, for example 2-23 in this case.

General Note

TT Electronics reserves the right to make changes in product specification without notice or liability. All information is subject to TT Electronics' own data and is considered accurate at time of going to print.

TT Electronics | Roxspur Measurement & Control Ltd
2 Downgate Drive, Sheffield, S4 8BT, England | Ph: +44(0)114 244 2521
www.roxspur.com | sales@roxspur.com

Platon Metal Tube VA Gas or Liquid



DS1220

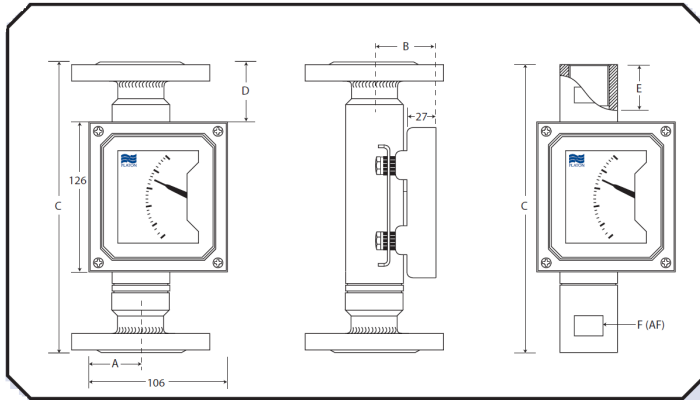

DIMENSIONS

Pipe Bore	15	25	50	80	100
A	51	45	42	42	39
B	48	51	66	87	100
C	250	250	250	300	400
D	51	49	49	75	113
E	26	34	27	N/A	N/A
F	27	41	60	N/A	N/A

INSTALLATION

1. All AVA meters are designed for vertical installations, with flow upwards. It is necessary to have 5 straight pipe diameters upstream and 2 straight pipe diameters downstream. Bends in two places should be avoided.
2. The upstream and downstream pipe bores should suit the normal size of the instrument, if possible.
3. Ensure that no ferromagnetic material is situated within 100mm of the indicator.
4. Before installing the meter, the pipeline should be flushed to remove any foreign matter, or swarf, likely to collect on the float unit and magnet.
5. For ultimate protection a filter should be fitted upstream of the meter to remove large particles.

Every effort has been made during the preparation of this document to ensure the accuracy of statements and specifications. However, we do not accept liability for damage, injury, loss or expense caused by errors or omissions made. We reserve the right to withdraw or amend products or documentation without notice.



Head Office: 2 Downgate Drive, Sheffield, S4 8BT, England
Tel: +44(0)114 244 2521 Fax: +44(0)114 243 4838



General Note

TT Electronics reserves the right to make changes in product specification without notice or liability. All information is subject to TT Electronics' own data and is considered accurate at time of going to print.

TT Electronics | Roxspur Measurement & Control Ltd
2 Downgate Drive, Sheffield, S4 8BT, England | Ph: +44(0)114 244 2521
www.roxspur.com | sales@roxspur.com