

Vitreous Enamelled Heavy Duty Tapewound Resistors

U400 Series

- **Very low resistance values**
- **Choice of terminations and mounting styles**
- **High overload capability**

OBSOLETE

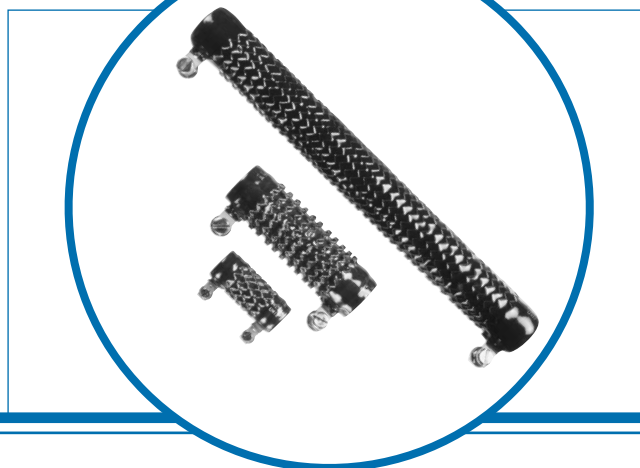

General Information

The U400 Series of resistors is particularly suitable for overload applications, due to the large energy absorption capability of the heavy tape element and careful matching of tube and enamel thermal characteristics.

The Welwyn range is based on six sizes of tube, each of which has a recommended dissipation which limits operating surface temperature to a maximum of 350°C.

The resistors may be fitted with tapping bands as required; these may also be used as adjusting bands.

Each style is available with the following choice of terminations:-

- Lugs for soldered or screwed connection Style U
- Pigtails for flexible connection Style UP
- Ferrules, permitting connection via spring mounting clips Styles UC and UCB

The U400 Series is designed for use with Welwyn type MD40 mounting brackets. and the UC400 Series with spring mounting clips

Electrical Data

		U412	U413	U414	U415	U416	U417
Power rating at 20°C*	watts	30	60	125	140	275	375
Resistance range	ohms	0R09 to 2R25	0R27 to 6R8	0R28 to 7R2	0R48 to 12R4	0R76 to 19R0	0R96 to 39R0
TCR range (-55 to +200°C).	ppm/°C	Typically: +75 Maximum: +200					
Resistance tolerance	%	10					
Values		Any value within the specified resistance range					
Ambient temperature range	°C	-55 to +350					

*Mounted horizontally with unobstructed bore.

Physical Data

Dimensions (mm)										See figs 2 to 6 for illustrations
Type max	A max	B nom	C nom	D nom	E max	F	G	H max	J max	
U412	53	28	13	5.7	6.8	26.5	M4	85	39	
U413	116	28	13	5.7	6.8	26.5	M4	150	39	
U414	102	36	19	7	9.8	32	M6	134	43	
U415	152	36	19	7	9.8	32	M6	184	43	
U416	216	36	19	7	9.8	32	M6	248	43	
U417	267	36	19	7	9.8	32	M6	299	43	

General Note

Welwyn Components reserves the right to make changes in product specification without notice or liability. All information is subject to Welwyn's own data and is considered accurate at time of going to print.

© Welwyn Components Limited · Bedlington, Northumberland NE22 7AA, UK
Telephone: +44 (0) 1670 822181 · Facsimile: +44 (0) 1670 829465 · Email: info@welwyn-tt.com · Website: www.welwyn-tt.com

Vitreous Enamelled Heavy Duty Tapewound Resistors

U400 Series

Construction

The stability and reliability of this range of resistors result from the use of best quality materials in the construction. A high purity ceramic tube is matched with nickel chromium or copper nickel alloy resistance tape and specially formulated enamel, ensuring the resistors withstand repeated heat cycling without damage. Connections between the resistance element and terminations are welded; other connections are brazed. Ferrules are anchored into the tubes with high temperature adhesive.

Terminations

Lugs (Figure 2) Solder coated nickel iron. Denoted by prefix 'U' to size reference, thus: U412.

Pigtails (Figure 3) 14/.193 mm copper, 150 mm minimum length. Denoted by prefix 'UP' thus: UP412.

Ferrule, electrically live (Figure 4) Nickel plated brass. Denoted by prefix 'UC' thus: UC412.

Ferrule, Electrically Isolated (Figure 5) Connection to resistor via solder coated nickel iron lugs. Denoted by prefix 'UCB' thus: UCB412.

Marking

The resistors are legend marked with type reference, resistance value, tolerance and manufacturing date code. Value marking conforms to IEC 62.

Solvent Resistance

The vitreous coating and marking are resistant to all accepted industrial cleaning fluids suitable for printed circuit boards.

Performance Data

		Maximum
Load: 1000 hrs at room temperature	$\Delta R\%$	5
Shelf life:		
12 months at room temperature	$\Delta R\%$	1
Humidity: 56 days	$\Delta R\%$	2

Overload

Very few applications are alike and it is not practicable to provide complete overload performance information in this publication.

The curves in Figure 1 are for guidance only, and Welwyn Components will give advice on specified applications.

The specification should define:

Peak power or current

Pulse duration and shape

Minimum time between successive pulses

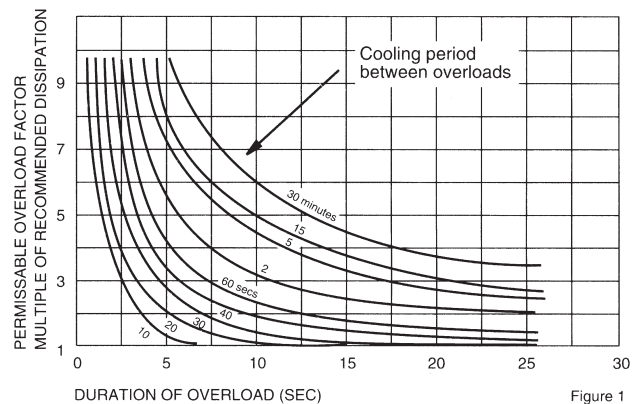

Figure 1

Figure 2. Style U

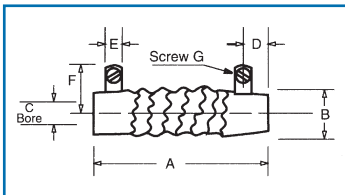

Figure 3. Style UP

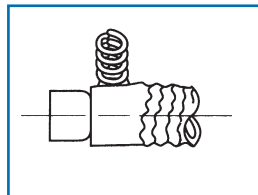

Figure 4. Style UC

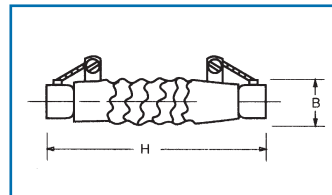

Figure 5. Style UCB

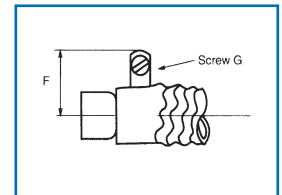
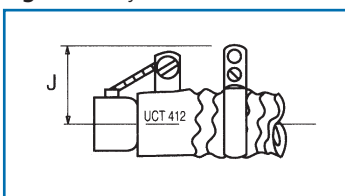

Figure 6. Style UCT



Tapped Resistors

(Figure 6) A tapping band can be fitted to resistors when required. Add 'T' to type reference when ordering, thus: UT412 or UCT412.

More than one band can be fitted to the larger resistors, the maximum number depending on resistor body length.

Application Notes

The recommended dissipation for the resistor hot spot temperature applies to resistors mounted horizontally. If the bore is completely blocked a 15% derating is recommended. However, wherever possible, resistors should be mounted vertically with unobstructed bore and under these conditions can be up-rated by 10%. This makes best use of the chimney

effect of the heated tube and will encourage a cooling system of air through the bore. Appreciable reduction of hot spot temperature can be achieved by arranging that resistors are subjected to some measure of forced draught. In general, it is effective to extract air from the resistor enclosure and arrange that an air inlet is adjacent to the bottom of the tubes.

Mounting Devices

Mounting bracket dimensions (mm) Fig. 7						
Resistor ref.	Bracket type	A nom.	B nom.	C max	D max	E nom
U412	MD42	70	81	20	25	5.2
U413	MD42	133	144	20	25	5.2
U414	MD43	124	140	28	30	5.2
U415	MD43	174	190	28	30	5.2
U416	MD43	238	255	28	30	5.2
U417	MD43	290	306	28	30	5.2

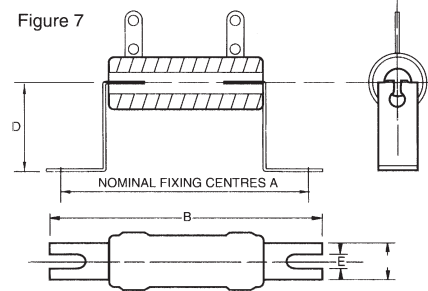

Ordering Procedure

Specify the type reference and quantity in units.

Mounting Clip dimensions (mm) Fig. 8												Auxiliary locking spring ref
Resistor ref.	Bracket type	A nom.	B max	C nom.	D max	E max	F max	G ± 0.2	H dia	J dia	K nom	
U414	MD3, MD6	120	141	49	33	32.0	19.0	6.4	4.0	6.3	9.5	MD18
U415	MD3, MD6	170	191	49	33	32.0	19.0	6.4	4.0	6.3	9.5	MD18
U416	MD3, MD6	234	255	49	33	32.0	19.0	6.4	4.0	6.3	9.5	MD18
U417	MD3, MD6	285	306	49	33	32.0	19.0	6.4	4.0	6.3	9.5	MD18

MD5 and 6 have an ear formed in the bottom surface of the bracket to prevent rotation on the mounting plate. The auxiliary locking springs ensure positive retention of the tube under severe mechanical shock conditions. See figure 8.

Ordering Procedure

Mounting clips (and auxiliary locking springs, when required): specify the type reference and quantity in units.

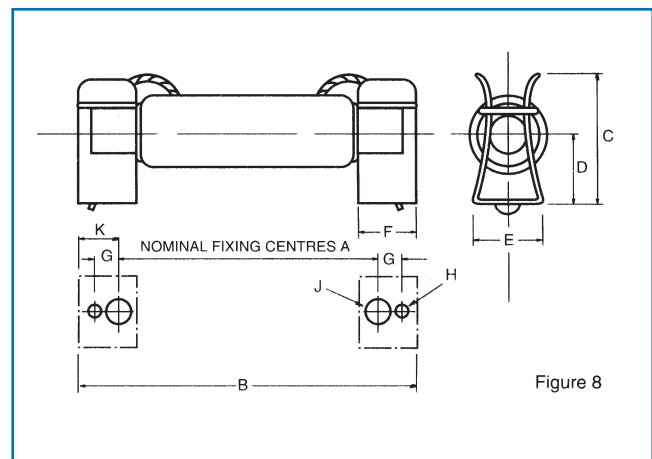

Ordering Procedure

Specify type reference, value and tolerance as shown in this example of U412 2R25 5%:

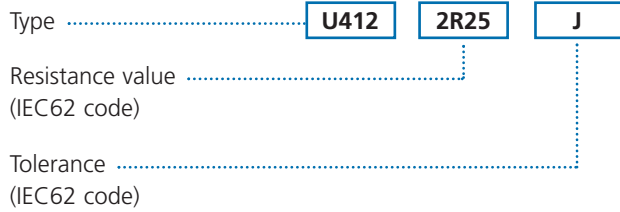

F	1%
G	2%
J	5%