

# HIGH ISOLATION VOLTAGE FLYBACK TRANSFORMER

By: Edgar C. Taculog  
Field Application Engineer, Asia  
TT Electronics

New TT Electronics AEC-Q200 qualified and certified transformers are optimized for use with a gate-drive optocoupler to improve and simplify the design of isolated power supplies.

## Overview

Transformers can often provide an inexpensive solution for a variety of applications. The purpose of the transformer is to isolate the secondary side of the circuit from the primary power source, transfer power efficiently from the electrical source to the target load and protect users from hazards like electric shock, fire and heat. The flyback transformer, which is an isolated version of a buck-boost transformer, does not in truth contain a transformer but a coupled inductor arrangement. When the transistor is turned on, current builds up in the primary and energy is stored in the core, this energy is then released to the output circuit through the secondary when the switch is turned off. The basic concept of this scenario can result in significant heat generation if not properly addressed.

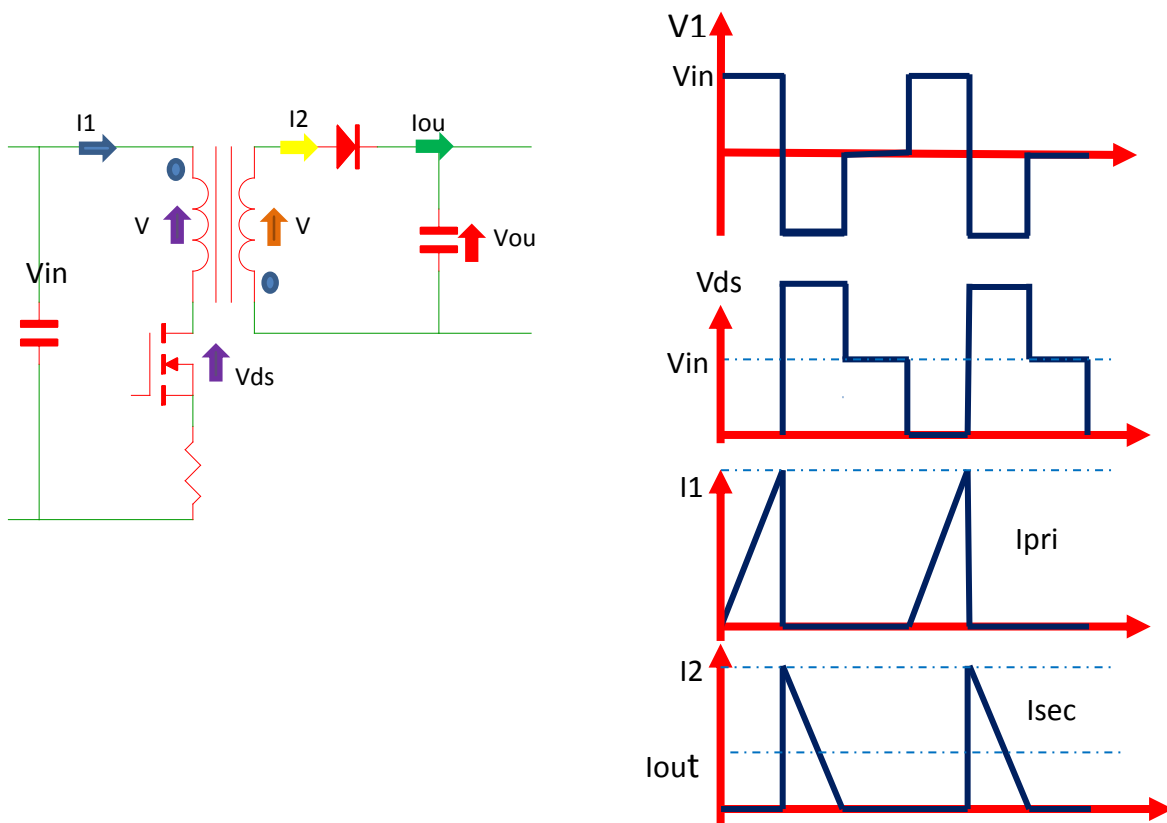

Figure 1: Flyback Converter in Discontinuous Mode

The HA00-10043ALFTR and HA00-14013LFTR line of transformers are designed specifically for use with Avago’s ACPL-32JT and ACPL-302J optocoupler ICs for automotive and industrial application respectively. The Avago devices are specifically used in a wide variety of applications that require high galvanic isolation so in designing these transformers materials that can meet the necessary creepage and clearance distances between conductors were taken into consideration. Likewise, the use of materials that can meet the UL94 V-0 flammability specification and a mechanical design able to withstand unintended drops and impacts are important.

Safety isolation requirements impose minimum dimensional limits for creepage and insulation thickness, which can waste a high percentage of a transformer core’s winding window area, especially in a small transformer. A bobbin also reduces the area available for windings. Triple insulated wire satisfies the insulation thickness requirement and eliminates the creepage requirement and is worth considering, especially for small transformers where creepage distances take up a large percentage of the window area.

Adequate isolation between power source and load, following SELV (safety extra-low voltage) circuit design principles, ensures equipment safety and protects operators from contact with high voltage circuits. TT Electronics’ HA00-10043ALFTR and HA00-14013LFTR transformers comply with regulatory safety requirements as stipulated for use with Avago’s ACPL-32JT and ACPL-302J devices.

The ACPL-32JT and ACPL-302J ICs are highly integrated power control devices that incorporate all the necessary components for a complete, isolated IGBT gate drive circuit. They feature a flyback controller for isolated DC-DC conversion, a high-current gate-driver, Miller current clamping, IGBT desaturation, and under-voltage lock-out (UVLO) protection with feedback.

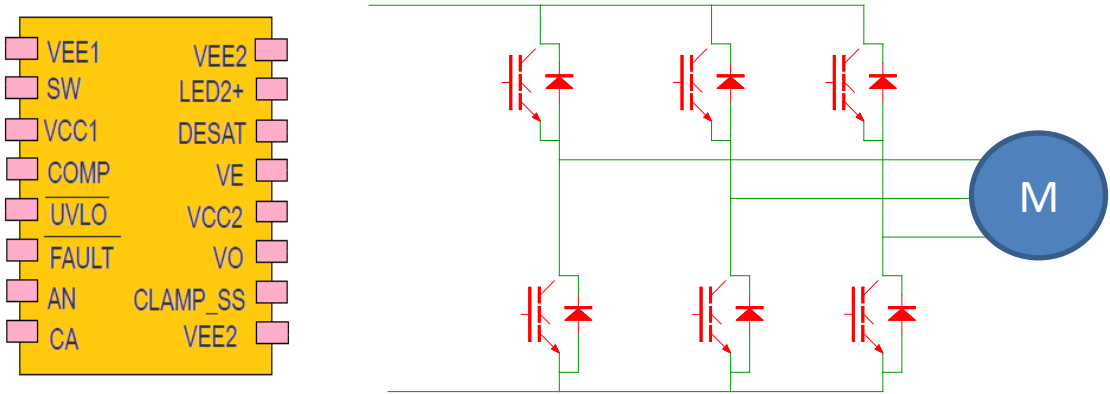

Figure 2: AVAGO Chipset driving a 3-phase motor

## Theory of Operation

Successfully implementing an isolated power supply is perhaps most critically dependent on the specification and design of its transformer. There are many factors that impact the design: cost, size, heat dissipation, and material selection. In addition to the usual list of requirements dealing with high-frequency isolated power supply transformer design, the following points should be carefully considered as well.

- Primary Inductance
- Turns Ratio
- Leakage Inductance
- Secondary Inductance
- Bias Current
- Winding Technique
- Target Application

Typically, the transformer turns ratio is chosen to maximize available output power. For low output voltages, an N:1 turns ratio can be used with multiple primary windings relative to the secondary to maximize the transformer's current gain (and output power). However, the SW (switch output) pin on the Avago device will see a voltage that is equal to the maximum input supply voltage plus the output voltage multiplied by the turns ratio. Together these conditions place an upper limit on the turns ratio for a given application. For lower output power levels, a 1:1 or 1:N transformer can be chosen for the absolute smallest transformer size. A 1:N transformer will minimize the magnetizing inductance (and minimize size), but will also limit the available output power. A higher 1:N turns ratio makes it possible to have very high output voltages without exceeding the breakdown voltage of the internal power switch.

There are no hard and fast rules to follow in establishing the optimum number of turns for each winding, but there are some general guidelines. An experienced magnetics engineer will first define the ideal turns ratios between windings to achieve the desired output voltages with a normal  $V_{IN}$ \* Duty Cycle.

When a specific core has been selected, the turns ratios will allow the actual number of turns to be calculated but unfortunately the results do not always provide the integral numbers required in practice. In such instances, a trial and error approach may be necessary, until the best compromise with integral turns is reached.

Looking at the ACPL-32JT/302J chips, we can see they operate from a nominal input voltage of 12VDC to produce a regulated output of 20VDC. The chipset primary side is powered directly from the source supply rather than from a bias winding within the transformer while the secondary side of the transformer powers the secondary side. The flyback configuration of 1:2 turns ratio results in an output voltage equal to  $2*V_{in}$ , with the output voltage providing proper biasing for the chipset secondary side. Inside the chipset is an integrated switch that also limits the primary current using a sense resistor.

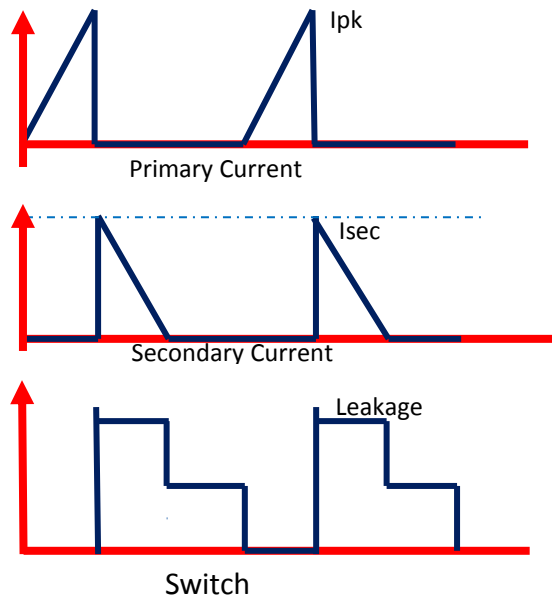

Figure 3. Switch Transition, Discontinuous Mode

Transformer leakage inductance (on either the primary or secondary) causes a voltage spike to appear at the primary after the output switch turns off. This spike is increasingly prominent at higher load currents where more stored energy must be dissipated. In most cases, a snubber will be required to avoid overvoltage breakdown at the switch node. To better protect the switching element, it is better to use snubbers to smoothen these generated spikes either using a passive RC network or a Zener diode combination if a more precise clamping level is needed. Transformer leakage inductance can be minimized by good design practice but is often neglected under the pressure of achieving a faster time to market.

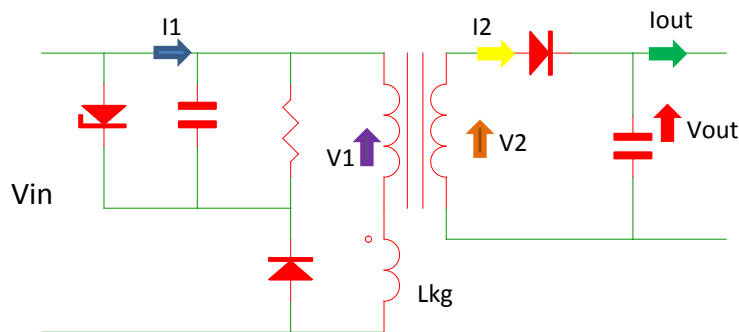

Figure 4. An RCD and Zener Clamp

Leakage inductance on the secondary in particular exhibits an additional phenomenon. It forms an inductive divider on the transformer secondary that effectively reduces the size of the primary-referred

flyback . This will increase the output voltage target by a similar percentage. Note that unlike leakage spike behavior, this phenomenon is load independent.

However, the primary current also circulates through the leakage inductance and causes an additional reverse voltage that adds to the previous one. If a RCD snubber is used, the clipping diode is forward biased and routes some current to the clamp network, transforming leakage energy into heat. Unfortunately, this leakage path also causes some of the energy stored in the gap to be transformed into heat. In other words, any current flowing in the leakage inductance forces the same current to flow through the mutual inductance. Furthermore, the leakage inductance delays the primary to secondary energy transfer until its current has dropped to zero. This parasitic inductance also diverts a substantial amount of the stored energy, impacting the open-loop gain and requiring a higher primary current that in turn will require the design of a larger core transformer.

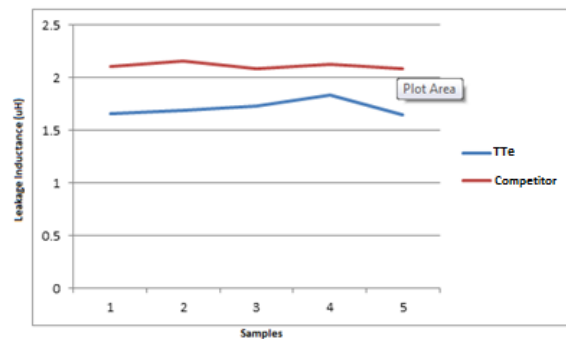

Figure 5: Leakage Inductance performance

When the switch is closed, input energy is stored in the core's gap with the total energy involved defined as:  $\text{Energy stored} = 1/2 I_{\text{peak}}^2 * L_{\text{peak}}$ . But when the switch opens, the voltage across the primary inductance reverses and the primary/secondary energy transfer should occur immediately. However, it takes a finite time until the transformer primary-side voltage approximately equals the output voltage. This is partly due to the rise time on the SW node, but more importantly is due to the transformer leakage inductance. The latter causes a very fast voltage spike on the primary-side of the transformer that is not directly related to output voltage. The leakage inductance spike is largest when the power switch current is highest.

When circuit board space is limited, especially in automotive applications, there are trade-offs in designing a bigger transformer - between better electrical but inferior EMI performance. For higher turns ratios, a transformer with a larger physical size is needed to deliver additional current and provide a large enough inductance value to ensure that the off-time is long enough to accurately measure the output voltage. Generally, the designer needs to determine if a centralized transformer design that requires a larger PCB board is better than using a distributed architecture where each transformer will require its own driver circuits. A larger transformer must operate at a lower power density because, as its size increases, the surface area for dissipating heat it proportionately less than its heat-producing volume.

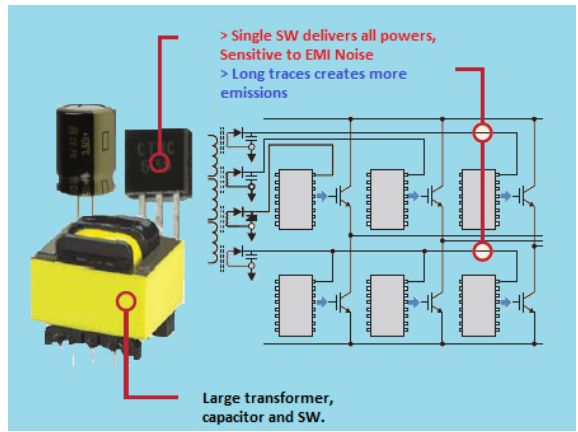

Figure 6: Centralized Power System

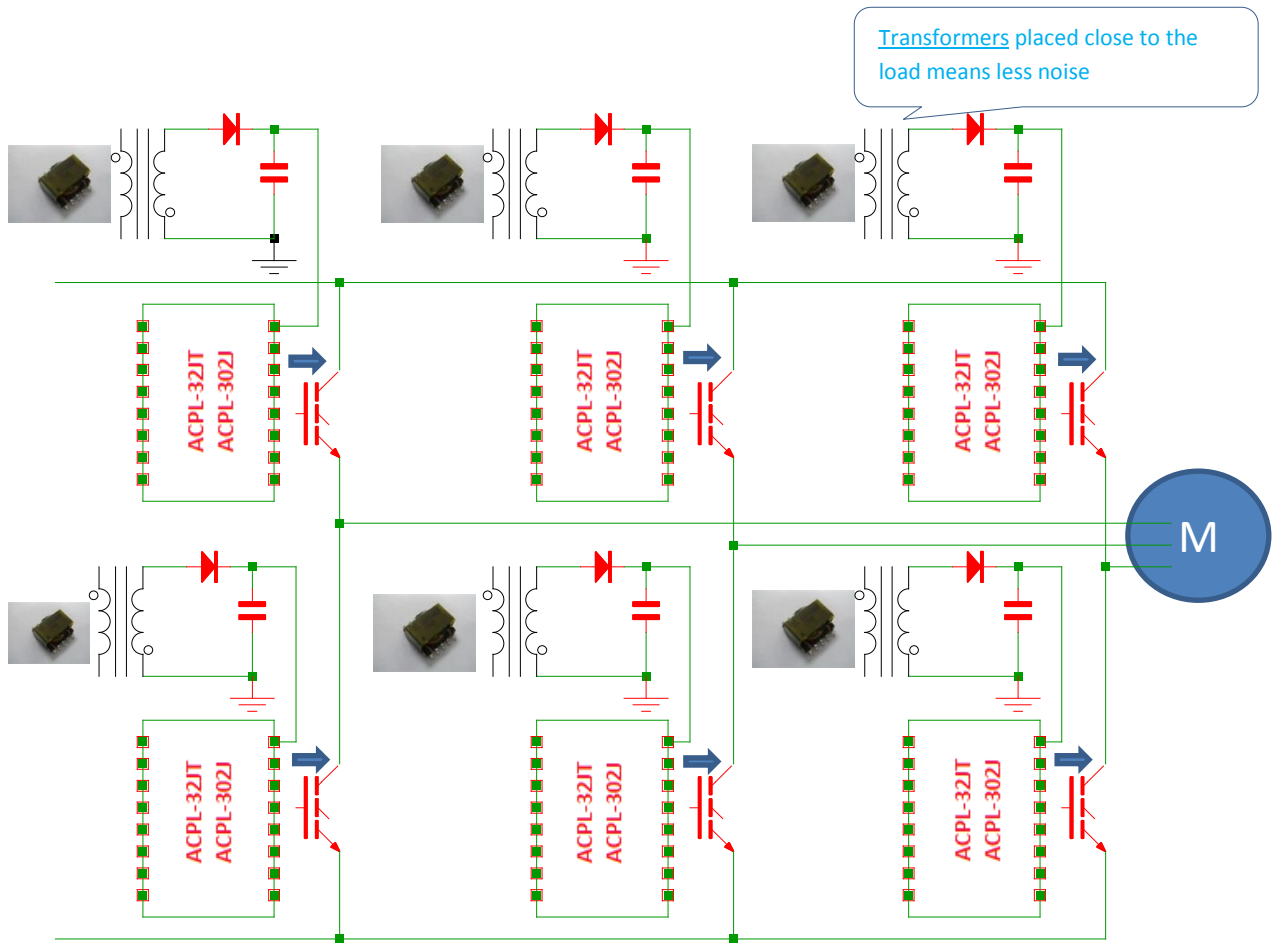

Figure 7: Distributed Power System

## TRANSFORMER DESIGN AND PERFORMANCE

HA00-10043ALFTR and HA00-14013LFTR are flyback, step-up transformers for DC-DC conversion with a high isolation voltage between primary and secondary. The design of the transformers takes into consideration all the requirements for operational robustness while providing the quality that TT Electronics has been known for over the years. One of the basic design criteria is selecting a core material with the right characteristics, each of which impacts on cost, size, frequency performance and efficiency. Other constraints relate to the volume occupied by the transformers, and weight, since weight minimization is an important goal in today's electronics. Finally, overall cost effectiveness is always an important consideration.

Perhaps not surprisingly, transformer efficiency, regulation, and heat dissipation are all interrelated. The minimum size of a transformer is basically determined either by a temperature rise limit, or by allowable voltage regulation, assuming that size and weight are to be minimized. Accordingly, the power handling capability of the core is related to  $W_a A_c$ , the product of the window area and core area. TT Electronics' engineers establish these criteria before commencing a design. The following criteria are also important parameters when designing magnetic components.

1. **Inductance** – Amount of magnetic field for a given current.
2. **Inductance with DC Bias** – Amount of inductance with DC current injected into the supply voltage applied to the magnetic component.
3. **Leakage Inductance** – Amount of inductance lost due to poor coupling, which is considered a circuit loss as good coupling is required for this application.
4. **Saturation or Rated Current** – The current level at which the inductance is reduced by 30%.
5. **Heating Current** – The current level at which the temperature of the magnetic component increases by 40° Celsius (*50° Celsius for some products*).
6. **Direct Current Resistance** – The resistance of the wire in an inductor coil.

Experience comes into play when dealing with problems related to losses. Transformer losses are limited by the temperature rise of the core surface at the center of the windings at the point when the temperature rise (°C) equals thermal resistance (°C/Watt) times power loss (Watts). As stated above, the appropriate core size for the application is the smallest core that will handle the required power with losses that are acceptable in terms of transformer temperature rise or power supply efficiency. In consumer or industrial applications, a transformer temperature rise of 40-50°C may be acceptable, resulting in a maximum internal temperature of 100°C. However, TT Electronics uses a variety of core geometries to achieve a lower temperature rise and reduces losses for better power supply efficiency.

Temperature rise depends not only upon transformer losses, but also upon the thermal resistance (°C/Watt) from the external ambient to the central hot spot. Thermal resistance is a key parameter, but very difficult to define with a reasonable degree of accuracy. It has two main components, internal thermal resistance between the heat sources (core and windings) and the transformer surface, and the external thermal resistance from the surface to the external ambient. Internal thermal resistance depends greatly upon the physical construction. It is difficult to quantify because the heat sources are distributed throughout the transformer. Internal resistance from surface to internal hot spot is not relevant because very little heat is actually generated at that point. Heat generated within the winding is

distributed from the surface to the internal core. Although copper has very low thermal resistance, electrical insulation and voids raises the thermal resistance within the winding.

This is a design area where expertise and experience is very helpful, especially in minimizing and crudely quantifying thermal resistance. In the final analysis, an operational check must be conducted with a thermocouple at the hot spot near the middle of the transformer, with the transformer mounted in a power supply prototype or evaluation board. Transformer losses should be examined under the worst-case conditions that the power supply is expected to operate at over long periods of time, not under transient conditions.

Ferrites inherently have a higher resistivity, which is conducive to their use in high frequency applications that result in lower eddy current losses. However, their permeability is generally lower, resulting in a greater magnetizing current, which must be dealt with snubbers and clamps in the end-customer's board design. Core size can be determined by a number of widely used methods, most are variations on the 'area product' obtained by multiplying the core's magnetic cross-section area by the window area available for the winding. However there are many variables involved in estimating the appropriate core size. Also, a core's power handling capability does not scale linearly with area product or with core volume. The thermal environment is equally difficult to evaluate accurately, whether with forced air or natural convection.

Some core manufacturers no longer provide area product information on their data sheets, often substituting their own methodology to make an initial core size choice for various applications.

### **What is AEC-Q200?**

AEC-Q200 qualification is the global standard for stress resistance that all passive electronic components must meet if they are intended for use within the automotive industry. The standard covers a range of applications that require automotive qualified components as shown in table 1 below. Parts are deemed to be "AEC-Q200 qualified" if they have passed a stringent suite of stress tests defined by the standard.

<b>Grade</b>	<b>Temperature Range</b>	<b>PASSIVE COMPONENT TYPE</b> (Maximum capability unless otherwise specified and qualified)	<b>Typical Application</b>
0	-50 to 150°C	Flat chip ceramic Resistors, X8R ceramic Capacitors	All automotive
1	-40 to 125°C	Capacitor networks, Resistors, Inductors, Transformers, Thermistors, Resonators, Crystals, and Varistors, all other ceramic and tantalum capacitors	Most underhood
2	-40 to 105°C	Aluminium Electrolytic Capacitors	Passenger compartment hotspots



3	-40 to 85°C	Film Capacitors, Ferrites, R/R-C networks and trimmer capacitors	Most passenger compartment
4	0 to 70°C		Non-automotive

Table 1: Stress Qualification for Passive Components

AEC-Q200-D splits the level of qualification required for different parts of the industry into five grades, numbered 0 – 4 as tabled above. Grade 0 is the most stringent, requiring testing throughout the -50°C to +150°C temperature range. Components graded to this level can be used in any application throughout the automotive industry, regardless of location within the vehicle. The level of testing required then decreases through the grades, grade 1 parts that are suitable for most under-the-hood uses are required to be tested through the -40 to +125°C temperature range, grade 2 parts are less stringently tested and are suitable for use in hot spots within the passenger compartments, grade 3 parts are for use within most of the passenger compartment, while finally grade 4 is the qualification grade used for non-automotive parts.

## Conclusion

TT Electronics’ AEC-Q200 certified HA00-10043ALFTR and HA00-14013LFTR high voltage isolation transformers offer a 10% higher saturation capability and 22% improvement in leakage inductance compared to competitive solutions. And through its field application engineers, TT Electronics can further help customers select materials suitable for high stress environments. Combining a better leakage signature with a higher saturation capability, applications using these transformers will have a reduced time to market with a faster turn-around time for design and development.

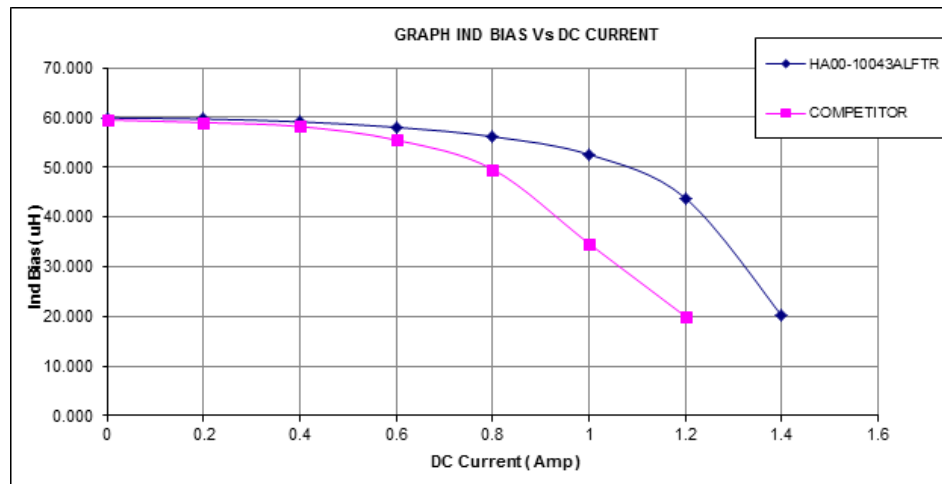

Figure 8: Bias Inductance

TT Electronics have been a supplier of automotive qualified magnetics such as transformers and Inductors over the years. As such, customers know we have the capability of delivering magnetic components with world class quality and reliability that can be use in any environmental condition under different stresses.