

P

Figure 2

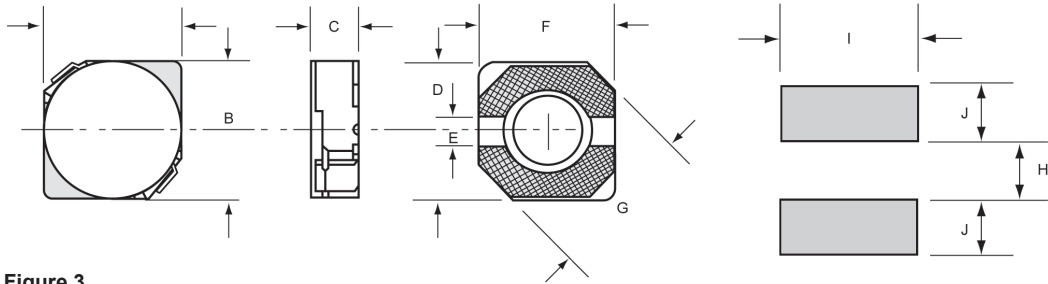
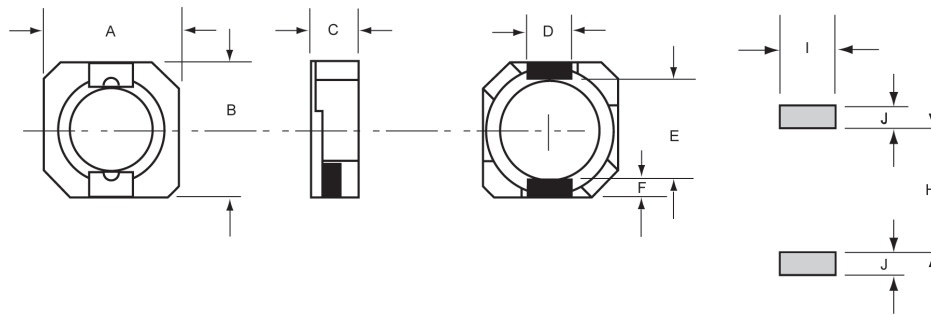

Figure 3



| Case Size | Figure | A | B | C Max. | D | E | F | G Max. | H | I | J |
|-----------|--------|------------|------------|--------|-----------|------------|------------|--------|-----|-----|------|
| 15 | 2 | 3.8 ± 0.5 | 3.8 ± 0.5 | 1.85 | 3.8 ± 0.3 | 1.1 ± 0.15 | 3.8 ± 0.3 | 5.5 | 1.1 | 4.5 | 1.7 |
| 20 | 2 | 4.7 ± 0.5 | 4.7 ± 0.5 | 2.1 | 4.5 ± 0.3 | 1.5 ± 0.15 | 4.5 ± 0.3 | 6.9 | 1.5 | 5.3 | 1.9 |
| 30 | 2 | 4.7 ± 0.5 | 4.7 ± 0.5 | 3.0 | 4.5 ± 0.3 | 1.5 ± 0.15 | 4.5 ± 0.3 | 6.9 | 1.5 | 5.3 | 1.9 |
| 40 | 2 | 5.7 ± 0.5 | 5.7 ± 0.5 | 2.0 | 5.5 ± 0.3 | 2.0 ± 0.15 | 5.5 ± 0.3 | 8.2 | 2.0 | 6.3 | 2.15 |
| 50 | 2 | 5.7 ± 0.5 | 5.7 ± 0.5 | 3.0 | 5.5 ± 0.3 | 2.0 ± 0.15 | 5.5 ± 0.3 | 8.2 | 2.0 | 6.3 | 2.15 |
| 60 | 2 | 6.7 ± 0.5 | 6.7 ± 0.5 | 3.0 | 6.5 ± 0.3 | 2.0 ± 0.15 | 6.5 ± 0.3 | 9.5 | 2.0 | 7.3 | 2.65 |
| 70 | 2 | 6.7 ± 0.5 | 6.7 ± 0.5 | 4.0 | 6.5 ± 0.3 | 2.0 ± 0.15 | 6.5 ± 0.3 | 9.5 | 2.0 | 7.3 | 2.65 |
| 80 | 3 | 10.0 ± 0.5 | 10.2 ± 0.5 | 4.0 | 3.0 ± 0.1 | 7.7 ± 0.3 | 1.2 ± 0.15 | - | 7.3 | 3.2 | 1.7 |

General Note

TT Electronics reserves the right to make changes in product specification without notice or liability.
All information is subject to TT Electronics' own data and is considered accurate at time of going to print.