

Slide Potentiometer

Model PSxx

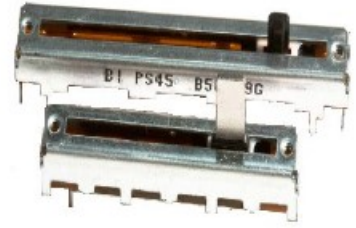

Features:

- 100,000 cycle life
- Metal/plastic lever
- RohS Compliant

Model Styles Available

Single Gang	PSxx-1
Dual Gang	PSxx-2

Electrical Specifications

Resistance Range, Ohms	1K — 1M
Standard Resistance Tolerance	± 20%
Resistance Tapers	A, B, C
Residual Resistance	Terminals 1 to 2: less than 10 ohms Terminals 2 to 3: less than 30 ohms
Input Voltage, Maximum	Linear B taper: 200 Vac Other tapers: 150 Vac
Power Rating, Watts (Single Unit / Dual Unit)	Linear B taper: 20mm: 0.1W / 0.05W, 30mm : 0.2W / 0.1W 45mm: 0.25W / 0.125W, 60mm : 0.2W / 0.2W Other tapers: 20mm: 0.05W / 0.025W, 30mm : 0.1W / 0.05W 45mm: 0.125W / 0.06W, 60mm : 0.1W / 0.1W
Dielectric Strength	300 Vac, 1 minute
Insulation Resistance, Minimum	100M ohms at 250Vdc / 1 minute
Sliding Noise	Less than 100mV
Gang Error	±3dB (-40dB to 0dB)

Notes:

¹ Specifications subject to change without notice

General Note

TT Electronics reserves the right to make changes in product specification without notice or liability. All information is subject to TT Electronics' own data and is considered accurate at time of going to print.

Slide Potentiometer

Model PSxx



Mechanical

Static Stop Strength, Minimum	5.0 Kgf/cm
Operating Force	10gf to 100gf
Detent Slip-out force	30gf to 200gf

Durability

Sliding Life	100,000 cycles
--------------	----------------

Ordering Information²

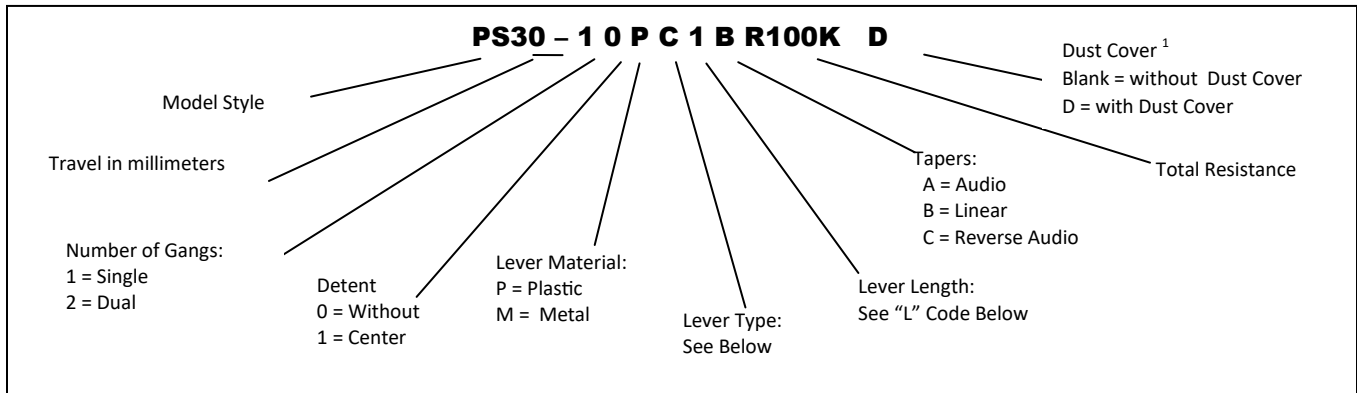

Standard Resistance Values, Ohms

1K	2K	5K	10K	20K	50K	100K	200K	500K	1 MEG
----	----	----	-----	-----	-----	------	------	------	-------

Notes:

¹ Dust Cover option not offered for levers less than 10 mm in length

² Contact our customer service for custom designs and features.

General Note

TT Electronics reserves the right to make changes in product specification without notice or liability. All information is subject to TT Electronics' own data and is considered accurate at time of going to print.

Plastic Lever Types

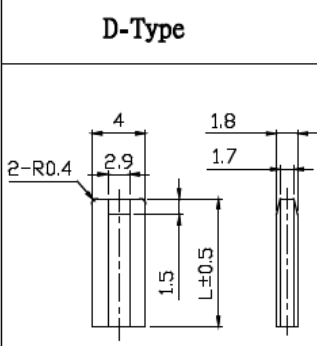
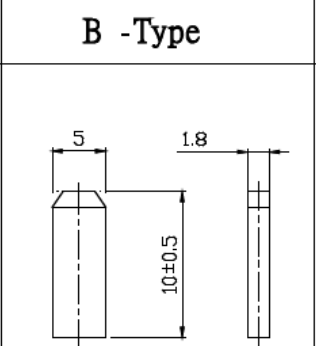
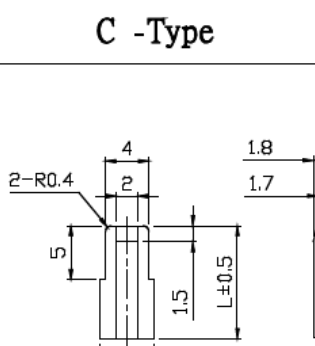
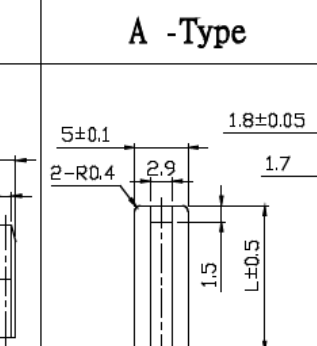
D-Type		B -Type		C -Type					A -Type				
													
L	5	L	10	L	10	12.5	15	18	20	L	5	8	10
CODE	1	CODE	1	CODE	1	2	3	4	5	CODE	1	2	3

Metal Lever Types

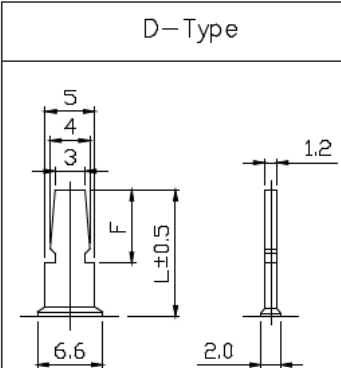
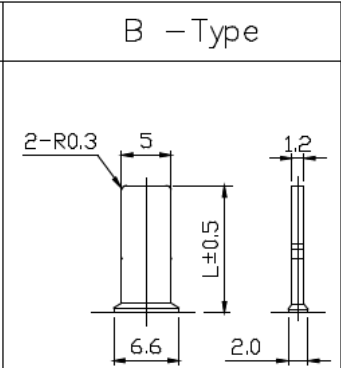
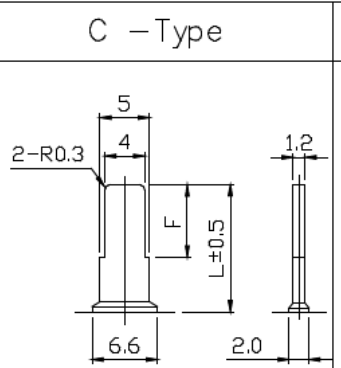
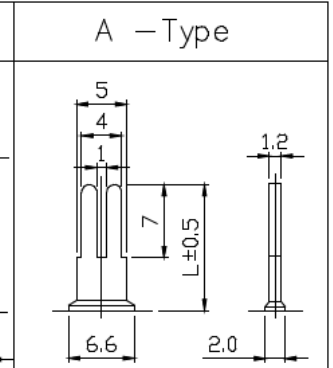
D-Type				B -Type			C -Type					A -Type			
															
L	15	20	25	L	6	7	10	L	10	15	17.3	20	25	L	10.4
F	10	10	10	CODE	1	2	3	F	7	10	10	10	10	CODE	1
CODE	1	2	3	CODE	1	2	3	CODE	1	2	3	4	5	CODE	1

Slide Potentiometer

Model PSxx



Outline drawing

PSxx-1 Single Gang

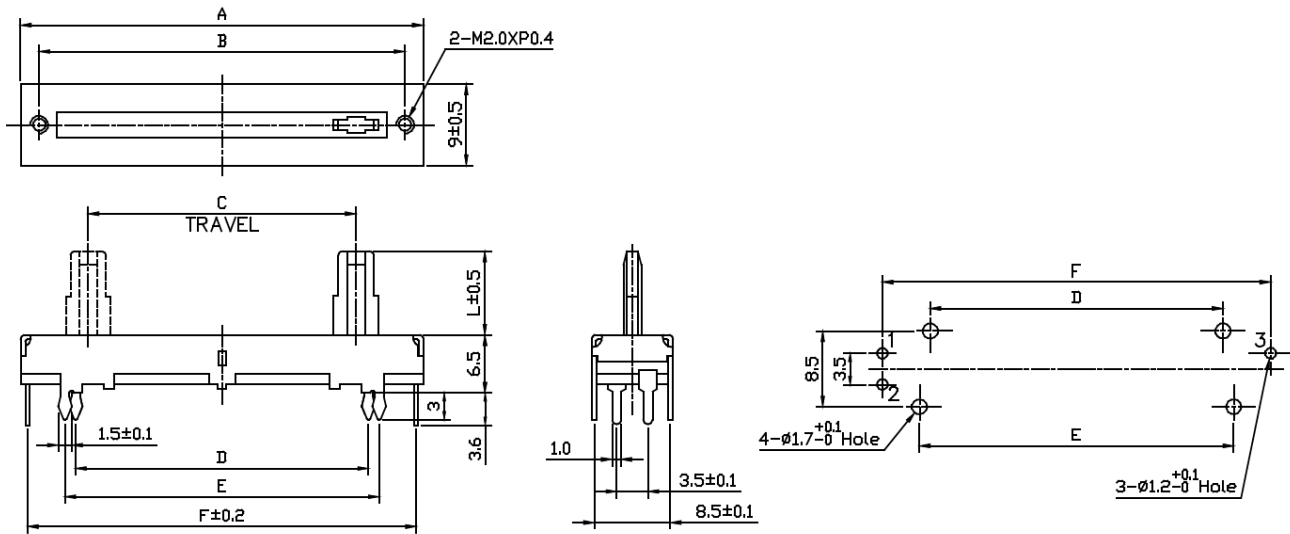

PSxx-2 Dual Gang

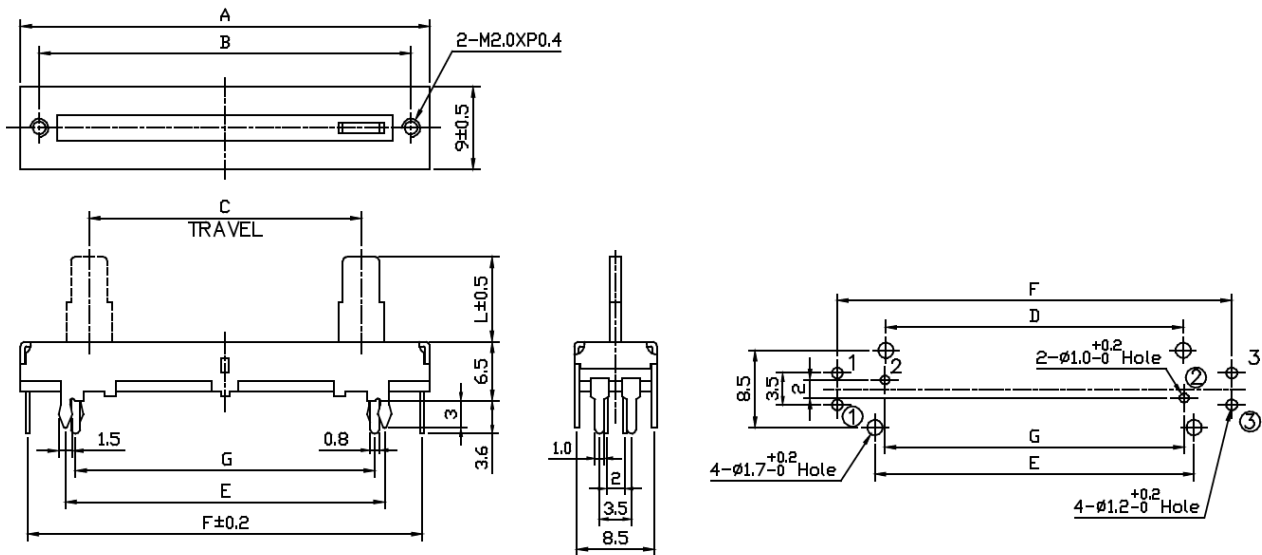

General Note

TT Electronics reserves the right to make changes in product specification without notice or liability. All information is subject to TT Electronics' own data and is considered accurate at time of going to print.

Slide Potentiometer

Model PSxx



MODEL	A	B	C	D	E	F	G
PS15-1	30	26	15	17.8	20.2	28.8	--
PS15-2	30	26	15	17.8	20.2	28.8	18
PS20-1	35	31	20	22.8	25.2	33.8	--
PS20-2	35	31	20	22.8	25.2	33.8	23
PS30-1	45	41	30	32.8	35.2	43.8	--
PS30-2	45	41	30	32.8	35.2	43.8	33
PS45-1	60	56	45	47.8	50.2	58.8	--
PS45-2	60	56	45	47.8	50.2	58.8	48
PS60-1	75	71	60	62.8	65.2	73.8	--
PS60-2	75	71	60	62.8	65.2	73.8	63

Circuit Diagram

PSxx-1 Single Gang

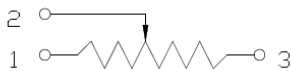

PSxx-2 Dual Gang

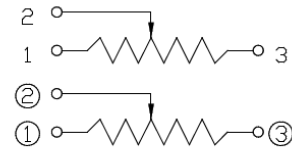

General Note

TT Electronics reserves the right to make changes in product specification without notice or liability. All information is subject to TT Electronics' own data and is considered accurate at time of going to print.